

EasyGo turnstile with ticket machine

Customer service that pays off



EasyGo with ticket machine V7/V21

Fail-safe turnstile with integrated ticket machine



Ticket machine V7

- > Reliable access control for paid entry
- > Stainless steel housing
- > Available with 2 or 3 arms



Ticket machine V21

- > 21" Full HD multi-touch display
- > Interactive LED lighting
- > Individual light colours
- > Lots of space for digital signage

The system can be supplemented as an option



Partition



Child entrance



3-arm turnstile

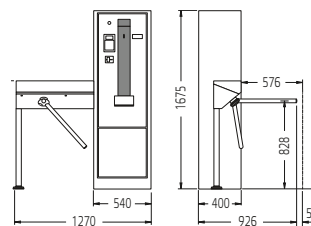

EasyGo with ticket machine, 2-arm

Entrance & refund principle

Customer service that pays off

■ **When entering the facilities**, your customers receive a voucher which can be redeemed in the store as a coupon. This results in additional revenue, consumer customers use your facilities free of charge and unauthorised persons remain outside.

With the entrance and refund principle, your investment costs will pay for themselves within a short time. Wanzl's reliable access controls play a key role here. The following example calculations demonstrate a rewarding model for your company.

Paid WC access

Example calculation for the retail sector				INDIVIDUAL PLANNING		
Amount	Voucher	Average spend/voucher	Example calculation			
€ 0.50	€ 0.50	€ 2.00	20% of all vouchers will not be redeemed 80% voucher redemption			
Toilet use	Number	in €	Average spend/voucher	Vouchers not redeemed	Total income	
Daily	50	€ 25.00	€ 80.00	€ 5.00	€ 85.00	
Monthly	1,200	€ 600.00	€ 1,920.00	€ 120.00	€ 2,040.00	
Annually	14,400	€ 7,200.00	€ 23,040.00	€ 1,440.00	€ 24,480.00	
The gross income (incl. VAT) per year is €24,480.00						

Payment systems

- Banknote reader with/without change function
- Coin changer
- Credit card terminal
- Credit card reader without pin pad for amounts up to €20
- NFC
- Lockable cash box
- Tokens (on request)

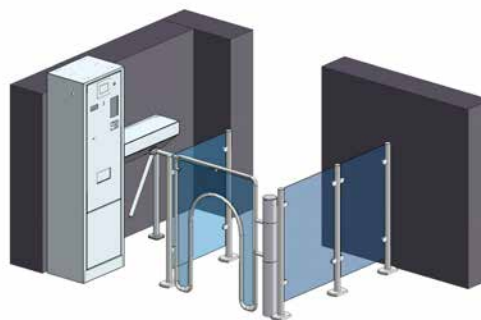

References



Center am Simmel-Hochhaus, Dresden



V-Markt, Kaufbeuren

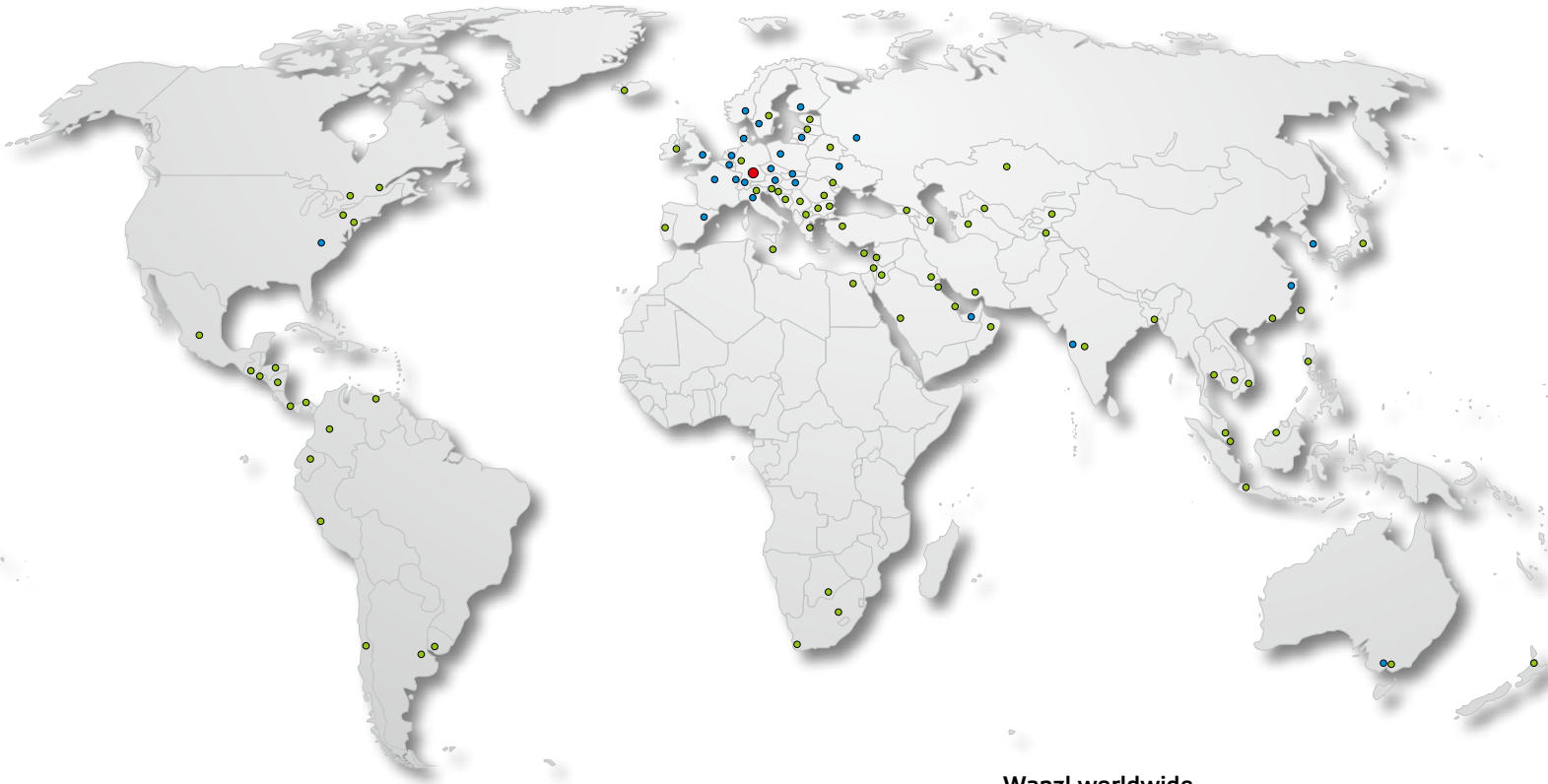

Wanzl worldwide

- Head Office
- Subsidiaries
- Partners



GERMANY

Wanzl Metallwarenfabrik GmbH
Rudolf-Wanzl-Straße 4
89340 Leipheim

Phone +49 (0) 82 21 / 7 29-0
Fax +49 (0) 82 21 / 7 29-1000

info@wanzl.com
www.wanzl.com

GREAT BRITAIN

Wanzl Ltd.
Europa House
Heathcote Lane
Warwick CV34 6SP

Phone +44 (0) 1926 / 45 1951
Fax +44 (0) 1926 / 45 1952

enquiries@wanzl.co.uk
www.wanzl.com

AUSTRALIA

Wanzl Australia Pty. Ltd.
97 Highbury Road
BURWOOD VIC 3125

Phone +61 (0) 3 / 98 08 22 99
Fax +61 (0) 3 / 98 08 22 66

info.au@wanzl.com
www.wanzl.com