

# Access Solutions

Guide customers and regulate access



# wanzl

INNOVATION  
MADE BY WANZL

CREATIVE CENTER  
**wanzl**

# Contents

|   |           |  |            |
|---|-----------|--|------------|
| CONTENTS                                | 3         |  |            |
| BE OPEN                                 | 5         |  |            |
| QUALITY_MADE BY WANZL                   | 7         |  |            |
| TECHNICAL PROJECT PLANNING              | 8         |  |            |
| SERVICE                                 | 9         |  |            |
| OVERVIEW                                | 10        |  |            |
| <b>01 GATES</b>                         | <b>12</b> | <b>04 ACCESS SOLUTIONS ACCESSORIES</b>         | <b>74</b>  |
| 01.01 Galaxy Gate                       | 14        | 04.01 Galaxy box                               | 76         |
| 01.02 Galaxy Gate with tall swivel arms | 16        | 04.02 PC control unit                          | 77         |
| 01.03 Example installations             | 22        | 04.03 FMCU                                     | 78         |
|   |           | 04.04 ESD                                      | 79         |
| <b>02 ENTRY AND EXIT SYSTEMS</b>        | <b>24</b> | <b>05 GUIDANCE ELEMENTS<br/>AND PARTITIONS</b> | <b>80</b>  |
| 02.01 Galaxy Port                       | 26        | 05.01 Stainless steel partition                | 82         |
| 02.02 eGate                             | 32        | 05.02 Classic guidance elements                | 84         |
| 02.03 Technoport                        | 36        | <b>06 VENDING UNITS</b>                        | <b>86</b>  |
| 02.04 eGate checkout                    | 40        | 06.01 Vending Unit V21                         | 88         |
| 02.05 Goods transportation gates        | 46        | 06.02 Vending Unit V15                         | 92         |
| 02.06 Swivel gates                      | 47        | 06.03 EasyGo with Vending Unit V7              | 96         |
| 02.07 Example installations             | 48        | 06.04 Example installations                    | 100        |
| <b>03 TURNSTILES</b>                    | <b>50</b> | <b>07 SOFTWARE</b>                             | <b>102</b> |
| 03.01 Sirio                             | 52        | 07.01 ETISS ERP                                | 104        |
| 03.02 EasyGo                            | 54        | 07.02 ETISS ERP with POS                       | 106        |
| 03.03 Portec                            | 58        | 07.03 ETISS NG                                 | 108        |
| 03.04 Transtec                          | 62        | 07.04 ETOSS                                    | 110        |
| 03.05 Low Atlas                         | 66        |  |            |
| 03.06 Atlas                             | 68        |  |            |
| 03.07 Example installations             | 72        |  |            |



# BE OPEN

Welcome your customers



CLASSIC TURNSTILE



TECHNOPORT R®

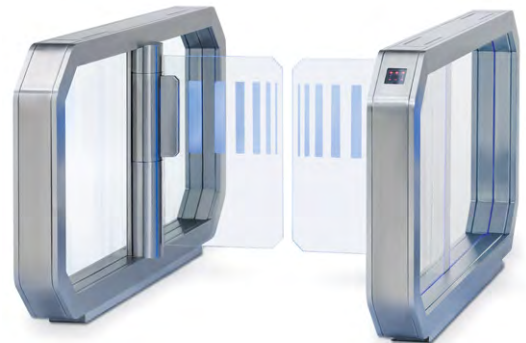

GALAXY GATE

■ **For over 50 years**, turnstiles, customer guidance systems and barriers have been a focal point of the Wanzl product range. Innovative, high-quality Wanzl security products are in use in all kinds of locations that require security against unauthorised access whilst granting unrestricted access to authorised personnel.

■ **The Wanzl product range features** a large number of motor-driven, electro-mechanical and mechanical security products for the control of entrances and exits in sporting and recreational facilities, office buildings and industrial complexes. In addition they have proven their value in public facilities such as libraries, railway stations and airports. Wanzl has the optimum solution for individual requirements, including high pedestrian frequency, sophisticated design or bespoke installation situations. Connection to security products and time recording systems, coin-operated and ticketing systems and other clearance signals is guaranteed, with appropriate interfaces.

***The world is changing.  
Take advantage of it!***

■ **Today, Wanzl employs** more than 4,600 people at 11 production sites worldwide. They work on new areas of business and products, ensuring exceptional product design, consistently high quality and a vast production range. This results in an innovative product range that will stand the test of time.

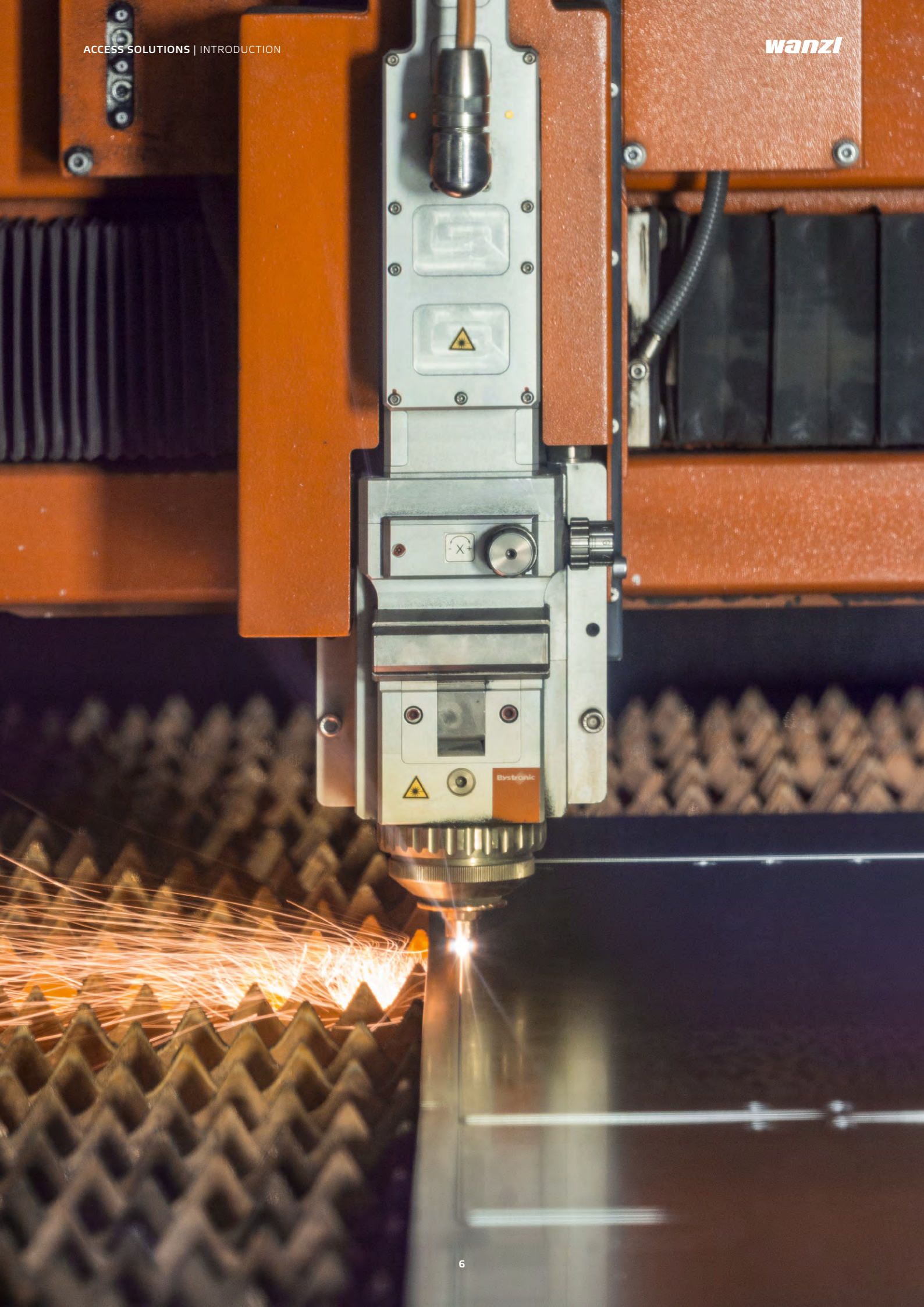

# Quality\_Made by Wanzl.

## Benefit from Wanzl expertise



EXPERTS IN WIRE AND TUBING



AUTOMATED IN-HOUSE PRODUCTION



VARIABLE SYSTEMS

### *Security product proficiency*

■ **The selection** of Wanzl access systems on offer is continually growing. Today's requirements demand new functions and features. Contemporary access systems from Wanzl are more functional and focus on current requirements.

### *Extensive production range*

■ **Wanzl's production relies** primarily on in-house manufacturing. This enables us to consistently meet high expectations for product quality, availability and short lead times.

### *Security expertise*

■ **Wanzl ensures security** by offering systems with great variability. Connection to security products and time recording systems, coin-operated and ticketing systems and other clearance signals is guaranteed through the use of interfaces. Building safety and fire prevention are essential in every planning process.

### *Wanzl guarantees*

■ **In addition to a standard warranty, we offer an extensive,** reliable and flexible network of qualified service personnel. You can contact us any day of the year on our service helpline.

# Technical Project Planning

Advice - Planning - Implementation

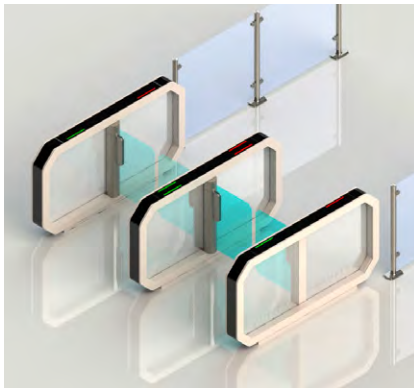

PROFESSIONAL PLANNING

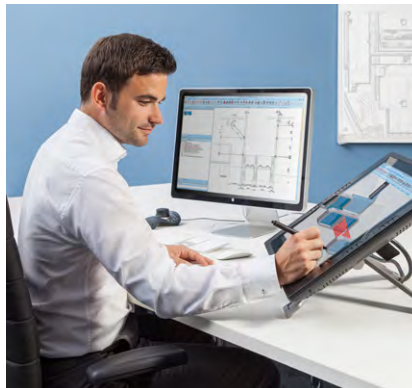

IN-HOUSE CAD DEVELOPMENT



CUSTOMER-SPECIFIC IMPLEMENTATION

## Professional Planning

■ **Project support.** Contact us in the first instance. We can provide support and advice, even if you're only considering a project.

We will be happy to use our experience to help you approach your construction project in the best possible way. From selecting the products to be used, appropriate and ideal placement and wiring, to connection to data processing systems, you can rely on Wanzl ideas and expertise.

■ **State-of-the-art 3D planning.** We use advanced CAD systems to create detailed drawings of solutions that reliably control access, help monitor access authorisations, and – where required – automatically cash up at any time. The plans are discussed and finely tuned in detail, taking structural conditions into account.

■ **Wanzl – your partner from the outset.** We have a wide range of advanced products for guiding customer flows and regulating access to restricted areas. We combine these with our many years of experience in the sector, to support you in the development and optimisation of access concepts. You will be impressed by our ideas and professional project service.



# Service

## Assembly, Maintenance & Repairs



MOBILE SERVICE



PROFESSIONAL AND EFFICIENT SERVICE



ASSEMBLY AND COMMISSIONING

### *Preserve the life of your assets*

■ **Assembly.** We offer complete understanding of the plan in every respect. We precisely understand planning drawings, in order to comply with and/or not disrupt operational procedures. Our experienced service technicians fit and install the hardware and software precisely to schedule.

■ **Maintenance.** To maintain the Wanzl quality we recommend regular maintenance of all components. Ongoing maintenance ensures that the value of your assets is preserved. Ask about **360° Wanzl Service** – your personal all-round service.

■ **Repair.** An experienced team of service technicians offers fast and professional customer service, including documentation, and deals with all service requests efficiently – from repairs to annual maintenance. With **360° Wanzl Service**, you can reliably pass this burden on to Wanzl.

■ **Wanzl Service.** To contact our professional customer service team, please use the telephone numbers listed online – a service technician will be with you in no time. There is a service support centre near to you.



*Your direct line to us:* See [www.wanzl.com](http://www.wanzl.com)



01 Gates

02 Entry and exit systems

03 Turnstiles

04 Accessories

05 Guidance elements and partitions

06 Vending Units

07 Software



---

# 01 Product overview

---

## 01.01 Galaxy Gate



01 BASE UNIT, TANDEM UNIT



01 ACCESS WITH TALL SWIVEL ARMS

---

## 01.02 Example installations



02 ENTRY AND EXIT SOLUTIONS

---

# 01 Gates



# 01.01 Galaxy Gate®

BE **OPEN** with cutting-edge control and monitoring technology

- > Side glazing and swivel arms made of premium toughened safety glass
- > Slimline stainless steel housing
- > Drive unit with integrated panic function



**GALAXY GATE** Standby

Figure: base and tandem unit.

Access for disabled people and suppliers is on the left side, with the right side for standard passage

Design pending



**GALAXY GATE**

Access denied: Red. Access granted: Green

**GALAXY GATE**

Access denied: Red



**Customisable**

Individually labelled swivel arms and side panes on request.



# 01.01 Galaxy Gate®

■ **Fast-opening swivel arms** made from toughened safety glass, combined with a smart sensor system, ensure immediate and reliable identity checking. Access to public areas is reliably controlled and restricted areas are effectively protected.

## Design

Stainless steel housing and drive unit. Swivel arms and side glazing made from single-pane safety glass. The toughened safety glass swivel arms are opened using state-of-the-art microprocessor-controlled, backlash-free drive technology, with opening periods that can be programmed on a variable basis. Closing function is automatic or signal-controlled. Furthermore, dynamically programmable inputs and outputs are offered. Standard equipment with integrated alarm system, individual voice output (MP3) and programmable WEAC control with WEB server option for control via smartphone.

## Optional Equipment

Climb-over and crawl-under alarm, LED operating status indicator, LED lighting and inscription on side panes and swivel arms, person frequency measurement, difference counting, random generator, LCD colour display (virtual function support), integration of various peripheral devices (FMCU), interruption-free power supply, base support.



**GALAXY GATE**  
Housing with matt black coloured plastic powder coating

## Accessories

Control program for external PC, control panel, unauthorised access alarm, emergency OPEN switch, external release button, Galaxy Gate tandem unit, Galaxy Port, tubing booms for wiring from the ceiling, guidance elements, and holders for peripheral devices.



| Galaxy Gate  |                                      |                                      |
|--|--------------------------------------|--------------------------------------|
| Basic layout   | Base unit                            | Tandem unit                          |
| Consists of:<br>- Stainless steel housing with toughened safety glass side glazing<br>- Electromotor drive unit<br>- Adjustable motor speed<br>- Integrated alarm system<br>- LAN interface<br>- Software-monitored sensors<br>- Interface with the reader: potential-free contacts<br>- Manufacturing standard:<br>DIN-ISO 12100-1/-2, DIN EN 60335-1<br><br>Swivel arms made of toughened safety glass (please order separately) |                                      |                                      |
| <b>Surface</b><br>Stainless steel  | <b>Prod. no.</b><br>23.00400.09-0000 | <b>Prod. no.</b><br>23.00600.09-0000 |
| On request: Housing with coloured plastic powder coating, covers with coloured plastic powder coating, or laminated  |                                      |                                      |

# 01.02 Galaxy Gate®

with tall swivel arms. State-of-the-art control and monitoring technology

- > Tall toughened safety glass swivel arms for maximum protection against climbing over
- > Security levels for various security requirements
- > Drive unit with integrated panic function



**GALAXY GATE Standby**  
Figure: base unit with swivel arms:  
1500 mm in height up to top edge.

Design pending

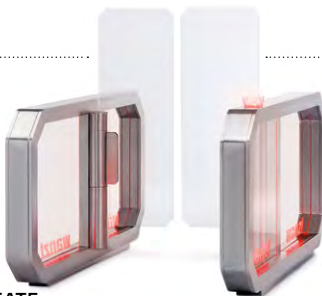

**GALAXY GATE**  
Access denied: Red

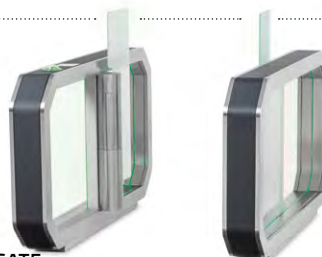

**GALAXY GATE**  
Access granted: Green





# 01.02 Galaxy Gate® with tall swivel arms

■ **Toughened safety glass swivel arms in a tall design** efficiently prevent anyone from climbing over the installation. Passage widths of up to 1125 mm are possible depending on the height. The smart sensor system ensures immediate and reliable identity checking.

## Design

Stainless steel housing and drive unit. Tall swivel arms and side glazing made from single-pane safety glass. The toughened safety glass swivel arms are opened using state-of-the-art microprocessor-controlled, backlash-free drive technology, with opening periods that can be programmed on a variable basis. Closing function is automatic or signal-controlled. Furthermore, dynamically programmable inputs and outputs are offered. Standard equipment with integrated alarm system, individual voice output (MP3) and programmable WEAC control with WEB server option for control via smartphone.

## Optional equipment

Climb-over and crawl-under alarm, LED operating status indicator, LED lighting and inscription on side panes and swivel arms, person frequency measurement, difference counting, random generator, LCD colour display (virtual function support), integration of various peripheral devices (FMCU), interruption-free power supply, base support.

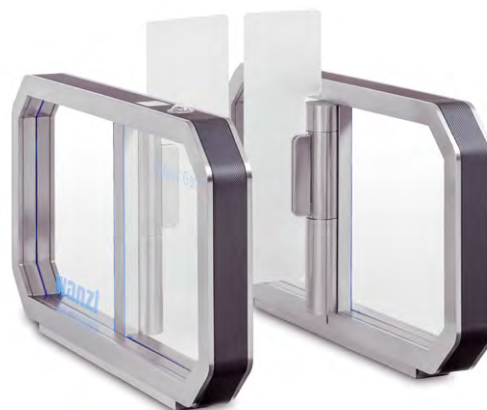



**GALAXY GATE**  
Housing covers laminated in a carbon look; swivel arms: 1250 mm in height up to top edge

## Accessories

Control program for external PC, control panel, LED operating status indicator, unauthorised access alarm, emergency OPEN switch, external release button, Galaxy Gate tandem unit, Galaxy Port, tubing booms for wiring from the ceiling, guidance elements, and holders for peripheral devices.



| Galaxy Gate with tall swivel arms   |   |  |
|---|---|--|
| Basic layout  | Base unit   | Tandem unit  |
| Consists of:<br>- Stainless steel housing with toughened safety glass side glazing<br>- Electromotor drive unit<br>- Adjustable motor speed<br>- Integrated alarm system<br>- LAN interface<br>- Software-monitored sensors<br>- Interface with the reader: potential-free contacts<br>- Manufacturing standard:<br>DIN-ISO 12100-1/-2, DIN EN 60335-1<br><br>Tall swivel arms made of toughened safety glass (please order separately) |  |  |
| <b>Surface</b><br>Stainless steel   | <b>Prod. no.</b><br>23.00500.09-0000  | <b>Prod. no.</b><br>23.00700.09-0000   |
| On request: Housing with coloured plastic powder coating, covers with coloured plastic powder coating, or laminated   |   |  |

# 01.01-01.02 Galaxy Gate®

## Technical information

### Functions

After release, the swivel arms open in the direction of passage. Once the user has passed through the system, the swivel arms close fully again. The integrated sensors monitor passage both when the arms are open and when they are closed. Attempted manipulation and unauthorised access are prevented and trigger an alarm.

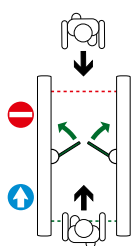

#### Two-directional operation

The Galaxy Gate makes passage from two directions possible. If people from both directions would like to pass through simultaneously, the first person to activate the reader unit for opening takes precedence.

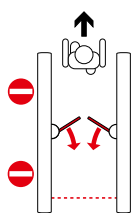

#### Individual opening

After each opening cycle, the swivel arms of the Galaxy Gate re-open fully, and only then can the next clearance take place.

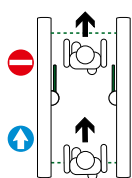

#### Multiple opening

Another person can clear the next opening cycle while the current opening cycle is running. The swivel arms of the Galaxy Gate stay open, and close when the last person has left the swivel area.

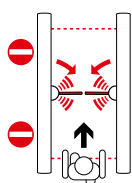

#### Guard against reverse passage

In the event of malfunction or if there is unauthorised access in the entry and exit direction, the reverse passage guard initiates the immediate closing of the swivel arms and/or activates an acoustic voice announcement or alarm signal.

#### Operating status indicator

Integrated LED strips signal the operating status of the Galaxy Gate in the entry and exit direction.

| LED status indicator                   |            |                                    |                                      |
|--|------------|------------------------------------|--------------------------------------|
|  | LED-strips | Toughened safety glass swivel arms | Toughened safety glass side sections |
| Release                                | Green      | Green                              |                                      |
| Alarm<br>Manipulation<br>Panic opening | Red        | Red                                | One colour,<br>adjustable colour     |
| Standby                                | Unlit      | Blue                               |                                      |

#### FMCU (optional)

Technical requirements can be implemented based on customers' specific requests. Updates and control parameters can be adapted remotely.

#### Monitoring sensor (optional)

Using 2D technology, the recording sensor system supplies precise data to the gate for monitoring the flow of people in the passage area (entry and exit). All attempts at manipulation and instances of unauthorised access are recognised and indicated.

#### Light grid (optional)

Reliably controls the flow of people in entry and exit direction.

#### Slow closing

To protect individuals and objects during passage. The swivel arm speed is braked, meaning the arms close at reduced speed.

#### Swivel arm manipulation

If one of the swivel arms is pushed (panic opening), held in place, or its movement is influenced, an alarm signal sounds. The swivel arms then immediately and automatically return to the closed position.



#### Escape route

In the event of an emergency, the swivel arms can be opened in both directions. They can be swivelled freely when not supplied with power and are reset automatically when the power is switched back on.

#### Emergency OPEN switch (optional)

After operation, the swivel arm automatically opens in the exit direction.



#### Fire alarm contact

Break contact connection to central fire alarm system. Automatic opening to allow wheelchair-accessible passage.

#### Alarm/silent alarm

In case of swivel arm manipulation, individuals climbing over or crawling under, unauthorised access and panic opening.

#### Acoustic voice announcement

Alarm sounds and voice announcements in MP3 format.

#### Feedback contact

Passage confirmation for external systems.

# 01.01-01.02 Galaxy Gate®

## Technical specifications

### Material/surface

Frame: Stainless steel, polished or coloured plastic powder coating.

Covers: Stainless steel, polished, coloured plastic powder-coated or laminated.

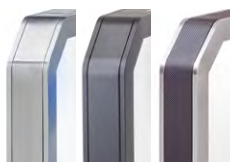

### Toughened safety glass swivel arms

Made of 8 mm single-plate safety glass. Sizes and passage widths as specified in the table. Special heights/widths available on request. Optional: Inscription, e.g. a company logo.

### Drive

Electromotor drive unit – low maintenance, backlash-free, long-lasting. Adjustable motor speeds, freely rotatable when not supplied with power.

### Sensor system

Light barriers, ceiling sensors and position sensors.

### Passage rate

For one-time opening, up to 30 people per minute (depending on the design).

### Interfaces, connecting devices

Potential-free closing contacts, control via the network. Securely integrated terminal strips for clear and easy cabling of peripheral devices. Where possible, the peripheral device is integrated into the housing. In combination with the Facility Management Control Unit (FMCU), additional devices and databases can also be built in, depending on the customer's preferences (see section titled Accessories: FMCU).

### Standard swivel arms

| Passage width in mm                   | 550 | 1000 | 1200 |
|---------------------------------------|-----|------|------|
| Height to top edge of swivel arm 860  | ☑   | ☑    | ☑    |
| Height to top edge of swivel arm 1250 | ☑   | ☑    | ☑    |
| Height to top edge of swivel arm 1500 | ☑   | ☑    | -    |

### Toughened safety glass panes

Made of 8 mm single-plate safety glass, securely integrated into the housing. Optional: Inscription, e.g. with a company logo.

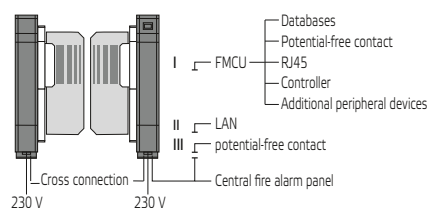

CONNECTION INTERFACES

| Galaxy Gate               | Single system  | Tandem unit    |
|---------------------------|----------------|----------------|
| <b>Basic layout</b>       |                |                |
| Electricity supply        | 100-240 V      | 100-240 V      |
| Rated frequency           | 50/60 Hz       | 50/60 Hz       |
| Power consumption         | max. 80 W      | 2x max. 80 W   |
| Rated current             | max. 0.85 A    | 2x max. 0.85 A |
| Residual current          | 30 mA          | 30 mA          |
| Recommended mains fuse    | 10 AT          | 10 AT          |
| Protection class          | I              | I              |
| Degree of protection      | IP20           | IP20           |
| Ambient temperature       | +5°C to + 50°C | +5°C to + 50°C |
| Weight without swivel arm | 2 x 90 kg      | 130 kg         |

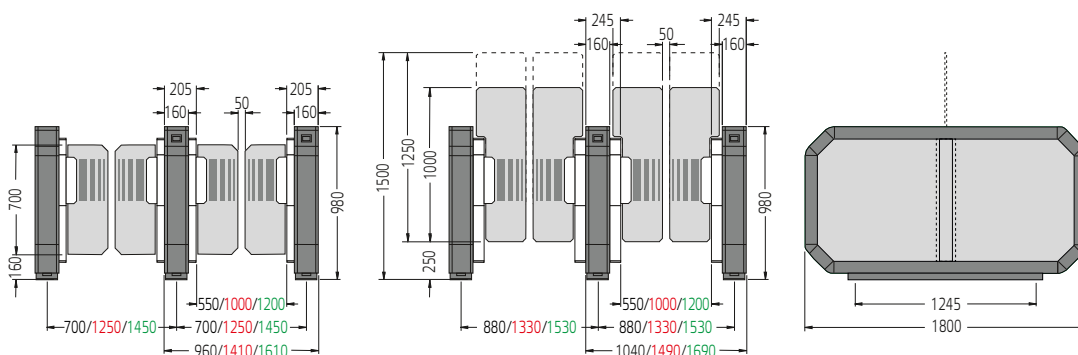

**Installation surfaces**  
Concrete foundation C25/30 or ground with a minimum compressive strength of 25 N/mm<sup>2</sup>, flatness tolerance of +/- 5 mm per installation surface.

GALAXY GATE

GALAXY GATE WITH TALL SWIVEL ARMS

# 01.01-01.02 Galaxy Gate®

## Accessories

### Indication of clearance

The coloured LED light indicates the following to the visitor:  
 GREEN – permanently open or authorisation successful, passage is released.  
 RED – opposite direction or no passage due to failed or incorrect authorisation, or manipulation.  
 Prod. no. 23.35071.95-0000

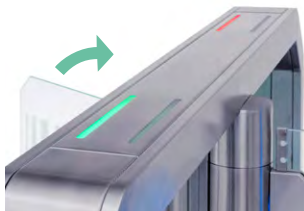

### Operating status indicator

LED light illuminates the printed or sandblasted motif. The colour changes depending on the operating status.  
 Prod. no. 23.46258.09-0000

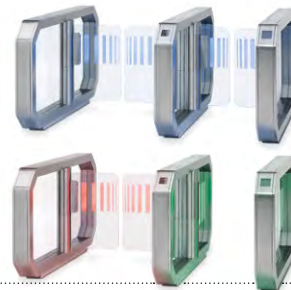

### Side glazing lighting

LED light illuminates the printed or sandblasted logo. The colour can be freely selected.  
 Prod. no. 23.32585.95-0000



### Info screen on the Galaxy Gate frame

Users receive clear instructions on how to interact with the gate.  
 Prod. no. 23.07052.95-0000  
 Only in combination with an FMCU.



### WEB control panel

A web browser and web server<sup>1)</sup> are required for this.  
 A WLAN router is required for mobile devices.  
 Prod. no. 23.88171.95-0000



### Reader units

A wide range of reader systems can be installed to review access authorisation:

- Palm vein scanners
- Facial recognition
- Fingerprint
- Iris recognition
- RFID or NFC
- Barcode or QR code
- "Swallowing" card reader

Existing reader units can be integrated.



### Control program for external PC

Software for operating the systems, to be installed on a PC that is already in place on-site.  
 Prod. no. 23.79480.00-0000  
 Required: Web server<sup>1)</sup>.

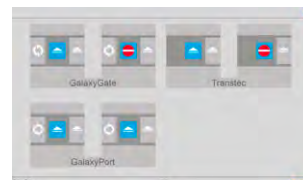

### Touchscreen PC as a control panel

Standalone touchscreen PC for operating the systems.  
 Prod. no. 98.76806.00-0000  
 Required: Web server<sup>1)</sup>.



### Galaxy box

"Swallowing" card reader, standard version with info screen.  
 Prod. no. 23.35528.09-0000  
 For detailed information, see section titled Accessories: Galaxy box



### Control Panel

For controlling the system.  
 Individual release in direction of passage or exit,  
 continuous release.  
 With connection cable  
 10 m Prod. no. 98.76599.00-0000  
 30 m Prod. no. 98.76884.00-0000



# 01.01-01.02 Galaxy Gate®

## Radio remote control

For controlling the system.  
Individual release in direction  
of passage or exit,  
continuous release.  
Prod. no. 98.73693.00-0000



For manual opening:

**Button**, 5 m cable

Prod. no. 23.79249.95-0000

**Mushroom button**, 5 m cable

Prod. no. 98.73449.00-0000

**Foot-operated switch**, 5 m cable

Prod. no. 98.72775.00-0000



## Emergency open switch

Following operation, passage  
in the exit direction opens  
automatically.  
Prod. no. 98.78947.95-0000

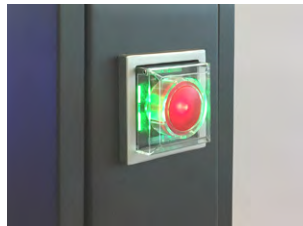

## External emergency open button

Following operation, passage  
in the exit direction is  
automatically opened.  
Prod. no. 98.74316-0000



## Light grid

Reliably controls the flow of  
people in entry and exit direction.  
Prod. no. 00.48732.00-0000

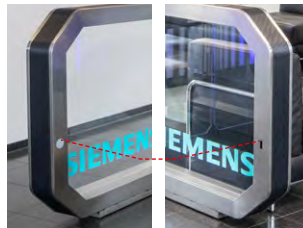

## Ceiling radar

With movement detector for  
early opening in the direction  
of passage.  
Prod. no. 98.73226.00-0000



## Tubing boom

Simple wiring from above.  
Prod. no. 23.73943.09-0000



## ESD

Portable measuring instrument  
and shoe test electrode.  
Prod. no. 98.74210.95-0000



## WLAN router

Remote control via mobile devices.  
Prod. no. 23.88171.95-9016



## Switch port

Connection of several LAN devices.  
Prod. no. 98.76784.00-0000



## Base support

Set

Prod. no. 23.62078.50-0000

## Packing plate (not shown)

For side cabling.

Prod. no. 23.45354.73-9005

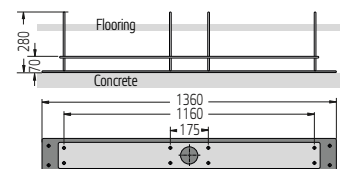

## Assembly plate

For Galaxy Gate use at a variety  
of locations, for additional  
systems at major events, etc.  
Prod. no. 23.89565.95-0000

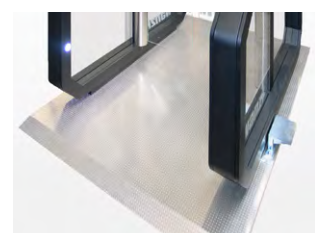

<sup>1)</sup> WENI control web server accessories  
Prod. no. 98.76287.00-0000  
Network card for attachment on  
the WEAC 2 control circuit board



Patch cables: 5 m Prod. no. 98.74362.00-0000  
15 m Prod. no. 98.74364.00-0000  
RJ45 UTP LAN adapter for patch cables Prod. no. 98.74510.00-0000

# 01.03 Example Installations

*The Galaxy Gate – attractive and functional*

- > Sport, fitness and leisure facilities
- > Public institutions, airports, trade fairs and exhibitions
- > Personnel access points for companies and offices



Fig. 1

**GALAXY GATE**  
Base and tandem unit (two passage widths), laminated covers, swivel arms with customised inscription, stainless steel partition

Fig. 2

**GALAXY GATE**  
Base unit, coloured plastic powder-coated cover, swivel arms with customised inscription

Fig. 3

**GALAXY GATE**  
Base and tandem unit, laminated covers, side panes with customised inscription, stainless steel partition

Fig. 4

**GALAXY GATE**  
Base and tandem unit, double Galaxy Port, stainless steel partition

Fig. 5

**GALAXY GATE**  
Base unit, Transtec turnstile, upright for card reader, stainless steel partition



# 01.03 Example Installations

■ **Tried and tested in many areas of use.** Galaxy Gate ensures user-friendly, economical, and future-proof management of entry and exit points.

Fig. 1  
**GALAXY GATE**  
 Base and tandem unit, side panes with customised inscription, stainless steel partition

Fig. 2  
**GALAXY GATE**  
 Base and two tandem units, plastic powder-coated frame, laminated covers

Fig. 3  
**GALAXY GATE**  
 Base and two tandem units

Fig. 4  
**GALAXY GATE**  
 Base unit, stainless steel partition, Classic guidance elements

Fig. 5  
**GALAXY GATE**  
 Base unit on assembly plate, coloured plastic powder-coated frame and covers, stainless steel partition on assembly plate

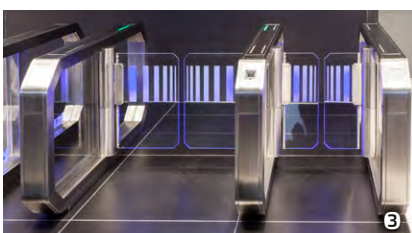

# 02 Product overview

## 02.01 Galaxyport



01 SINGLE SYSTEM

## 02.02 eGate®    02.03 Technoport®



02 DOUBLE SYSTEM



03 DOUBLE SYSTEM

## 02.04 eGate® Checkout



04 DOUBLE SYSTEM

## 02.05 Goods transportation gates



05 WITH UPRIGHT

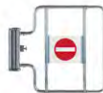

05 WITH FLANGE

## 02.06 Swivel gates



06 WITH UPRIGHT

## 02.07 Example installations



07 ENTRY AND EXIT SYSTEMS



## 02 Entry and exit systems



# 02.01 Galaxyport

*Cutting-edge technology for wheelchair-accessible access*

- > Toughened safety glass swivel arms for passages up to 1200 mm
- > LED glass dome with integrated RFID reader
- > Sensor-controlled two-way direction detection



**GALAXYPORT**  
Standby  
swivel arm height 700 mm



**GALAXYPORT**  
Access granted: Green



**GALAXYPORT**  
Access denied: Red



# 02.01 Galaxyport

■ **Galaxyport access points** open in two directions, either using the control panel or an RFID reader integrated into glass dome as preferred. The integrated sensor system detects the direction in which the toughened safety glass swivel arm needs to enable passage.



**GALAXYPORT**  
Free passage  
with tall swivel arm

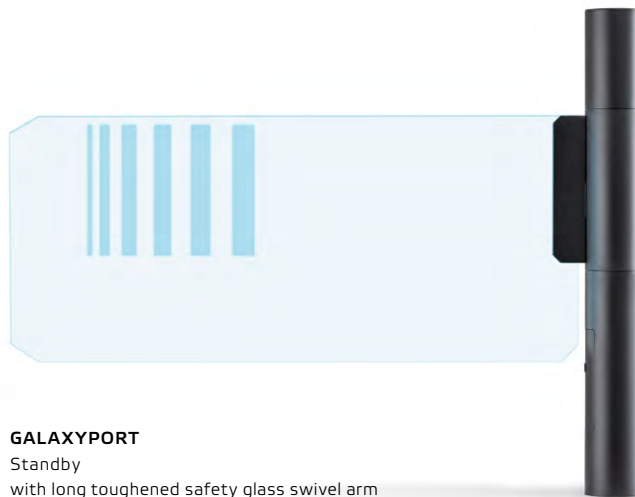

**GALAXYPORT**  
Standby  
with long toughened safety glass swivel arm

## Design

Stainless steel upright, toughened safety glass swivel arm is opened using state-of-the-art microprocessor-controlled drive technology, adjustable opening period, signal-controlled closing function, programmable WEAC controls with web server for control via smartphone, integrated alarm system (e.g. an unauthorised access alarm), climb-over and crawl-under alarm, release and alarm indication integrated into the glass dome, LED operating status indicator as swivel arm illumination.



**GALAXYPORT**  
Key switch

## Accessories

Control program for external PC, control panel, emergency OPEN switch, external release button, monitoring sensor, WEB control panel, base support, FMCU, LCD colour display with separate upright, Galaxy Gate, guidance elements, holders for peripheral devices. Can be released in two directions using various external readers, a control panel or an integrated RFID reader.



**GALAXYPORT AND GALAXYPORT GO**  
Release and alarm indication for both directions on the glass dome via integrated LED lighting.

| Galaxyport  | Basic Galaxyport  | Galaxyport   | Galaxyport Go   |
|---|---|--|---|
| <b>Basic layout</b><br>Consists of:<br>- Stainless steel housing<br>- Electromotor swivel unit<br>- Adjustable motor speed<br>- Integrated alarm system<br>- LAN interface<br>- Software monitoring<br>- Interface with the reader: potential-free contacts<br>- Manufacturing standard:<br>DIN-ISO 12100-1/2, DIN EN 60335-1<br>Swivel arms made of toughened safety glass (please order separately) |  |  |  |
| <b>Surface</b><br>Stainless steel<br>Plastic powder coating   | <b>Prod. no.</b><br>23.00900.09-0001<br>On request                                  | <b>Prod. no.</b><br>23.00900.09-0002<br>On request                                   | <b>Prod. no.</b><br>23.00900.09-0000<br>On request                                    |

## 02.01 Galaxyport

### Technical information

#### Functions

After release by the integrated RFID reader, radar or control panel, the swivel arm opens in the direction of passage. Sensors on both sides detect which side a person is coming from. Once the user has passed through the system, the swivel arm closes fully again. The integrated sensors monitor passage both when the arms are open and when they are closed. LEDs in the glass dome and on the toughened safety glass swivel arm indicate release and manipulation. Attempted manipulation and unauthorised access are prevented, and trigger an alarm.

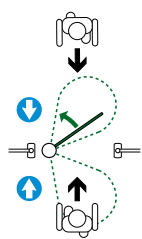

#### Two-directional operation

The Galaxyport allows for passage from two directions.

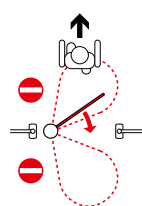

#### Individual opening

After each opening cycle, the swivel arm on the Galaxyport closes fully.

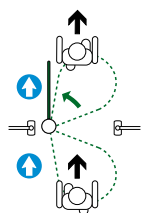

#### The control unit can be used to activate a permanently open function

In addition to the individual open function, the control unit can also be used to activate the permanently open function. This must then be reset on the control unit.

#### Operating status indicator

The illuminated release and alarm indication in the glass dome and illuminated toughened safety glass swivel arms indicate the operating status (optional).

| LED status indicator             |                    |                                   |
|----------------------------------|--------------------|-----------------------------------|
|                                  | Glass dome         | Toughened safety glass swivel arm |
| Release                          | Green              | Green                             |
| Alarm/Manipulation/Panic opening | Blinking red/green | Red                               |
| Standby                          | Red                | Blue                              |

#### FMCU (optional)

Technical requirements can be implemented based on customers' specific requests. Updates and control parameters can be adapted remotely.

#### Monitoring sensor (optional)

Using 2D technology, the recording sensor system supplies precise data to the Galaxyport for monitoring the flow of people in the passage area (entry and exit). All attempts at manipulation and instances of unauthorised access are recognised and indicated.

#### Swivel arm manipulation

If one of the swivel arms is pushed on, held in place, or its movement is influenced, an alarm sounds. At the same time, the toughened safety glass swivel arm lights up in red and the release indicator on the glass dome blinks, alternating red and green.



#### Escape route

Panic opening. Can be rotated freely when not supplied with power; setup is configured automatically when the power is switched back on.



#### Fire alarm contact

Break contact connection to central fire alarm system. Automatic opening to allow wheelchair-accessible passage.

#### Emergency OPEN switch (optional)

After operation, the swivel arm is automatically open in the exit direction.

#### Alarm/silent alarm

In case of swivel arm manipulation, individuals climbing over or crawling under, unauthorised access and panic opening.

#### Technical specifications

| Equipment features  |                  |            |               |
|---|------------------|------------|---------------|
| Type  | Basic Galaxyport | Galaxyport | Galaxyport Go |
| Height (mm)   | 980              | 1050       | 1050          |
| Toughened safety glass swivel arm slot (mm)                         | 8                | 8          | 8             |
| Coupling tube   | -                | ☑          | ☑             |
| Coupling tube with LED display and glass attachment                 | -                | ☑          | ☑             |
| Coupling tube with integrated RFID reader                           | -                | -          | ☑             |
| LED swivel arm illumination   | ☑                | ☑          | ☑             |
| Control via the control panel                                       | ☑                | ☑          | ☑             |
| Control via an external release system, e.g. card reader or network | ☑                | ☑          | ☑             |
| Panic alarm   | ☑                | ☑          | ☑             |

# 02.01 Galaxyport

## Technical specifications

### Material/surface

Upright: Stainless steel, polished and brushed or coloured plastic powder-coated.



### Drive

Electromotor drive unit – low-maintenance, backlash-free, long-lasting. Adjustable motor speeds, freely rotatable when not supplied with power.

### Sensor system

Light barriers, ultrasound sensor and ceiling sensor system, position sensor.

### Passage rate

For one-time opening, up to 10 people per minute (depending on the design).

### Interfaces, connecting devices

Potential-free closing contacts, control via the network. Connection clamping strip for easy wiring of peripheral devices. Where possible, the peripheral device is integrated into the housing. In combination with the Facility Management Control Unit (FMCU), additional devices and data-bases can also be built in, depending on the customer's preferences (see section titled Accessories: FMCU).

### Toughened safety glass swivel arms

Made of 8 mm single-plate safety glass. Sizes and passage widths as specified in the table. Bespoke heights/widths available on request. Optional: Inscription, e.g. a company logo.

|                           | Passage width in mm |               |
|---------------------------|---------------------|---------------|
|                           | Single system       | Double system |
| Swivel arm height 500 mm  | max. 1200           | max. 2450     |
| Swivel arm height 700 mm  | max. 1000           | max. 2050     |
| Swivel arm height 1000 mm | 650                 | 550-1250      |
| Swivel arm height 1250 mm | 550                 | 550-1050      |

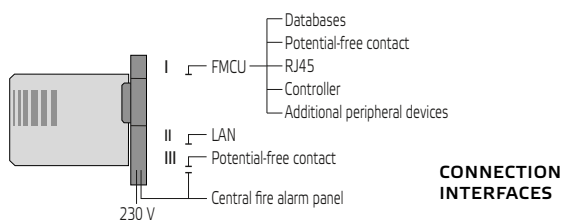

| Galaxyport                |                |
|---------------------------|----------------|
| Electricity supply        | 100-240 V      |
| Rated frequency           | 50/60 Hz       |
| Power consumption         | max. 80 W      |
| Rated current             | max. 0.85 A    |
| Recommended mains fuse    | 10 A T         |
| Residual current          | 30 mA          |
| Protection class          | I              |
| Degree of protection      | IP20           |
| Ambient temperature       | +5°C to + 50°C |
| Weight without swivel arm | 25 kg          |

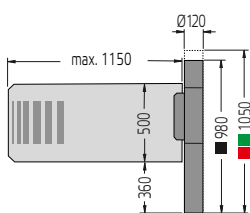

**GALAXYPORT**  
with swivel arm, height 500 mm

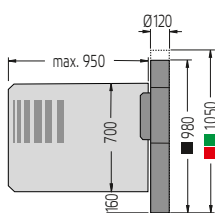

**GALAXYPORT**  
with swivel arm, height 700 mm

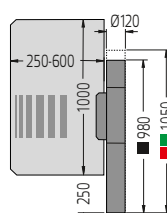

**GALAXYPORT**  
with swivel arm, height 1000 mm

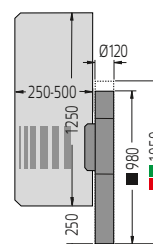

**GALAXYPORT**  
with swivel arm, height 1250 mm

**Installation surfaces**  
Concrete foundation C25/30 or ground with a minimum compressive strength of 25N/mm<sup>2</sup>, flatness tolerance of +/- 5mm

## 02.01 Galaxyport

### Accessories

#### Release and alarm indicator

The colour of LED light in the upright communicates information to visitors.

GREEN: Free passage with automatic opening, or successful authorisation; passage is enabled.

RED: No passage due to failed or incorrect authorisation.

Switching between RED and GREEN: Manipulation of the swivel arm.

Prod. no. 98.76719.00-0000



#### Operating status indicator

LED light illuminates the printed or sandblasted logo. The colour changes depending on the operating status.

Prod. no. 98.78423.00-0000



System ready



Release



No passage

#### Info screen

Users receive clear instructions on how to interact with the gate.

On upright with base plate.

Prod. no. 23.07052.95-0000



#### WEB control panel.

A smartphone app, WLAN router and web server<sup>1)</sup> are required for this.

Prod. no. 23.88171.95-9016



#### Reader units

A wide range of reader systems can be installed to review access authorisation:

- Palm vein scanners
- Facial recognition
- Fingerprint
- Iris recognition
- RFID or NFC
- Barcode or QR code
- "Swallowing" card reader

Existing reader units can be integrated.



#### Control program for external PC

Software for operating the systems, to be installed on a PC that is already in place on-site.

Prod. no. 23.79480.00-0000

Required: Web server<sup>1)</sup>.

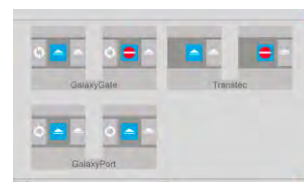

#### Touchscreen PC as a control panel

Standalone touchscreen PC for operating the systems.

Prod. no. 98.76806.00-0000

Required: Web server<sup>1)</sup>.



#### Galaxy box

"Swallowing" card reader, standard version with info screen.

Prod. no. 23.35528.09-0000

For detailed information, see section titled Accessories: Galaxy box



#### Control Panel

For controlling the system. One-time and permanent opening.

With connection cable

5 m Prod. no. 98.76762.00-0000

10 m Prod. no. 98.76763.00-0000

25 m Prod. no. 98.76764.00-0000



## 02.01 Galaxyport

### Radio remote control

For controlling the system.  
Individual release in direction  
of passage or exit,  
continuous release.  
Prod. no. 98.73693.00-0000



For manual opening:

**Button**, 5 m cable  
Prod. no. 23.79249.95-0000

**Mushroom button**, 5 m cable  
Prod. no. 98.73449-0000

**Foot-operated switch**, 5 m cable  
Prod. no. 98.72775.00-0000



### Emergency open switch

Following operation, passage  
in the exit direction opens  
automatically.  
Prod. no. 98.76947.95-0000



### External emergency open button

Following operation, passage in  
the exit direction is automatically  
opened.  
Prod. no. 98.74366.00-0000



### WLAN router

Remote control via mobile devices.  
Prod. no. 23.88171.95-9016

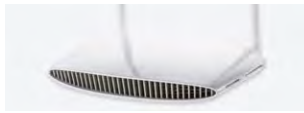

### Switch port

Connection of several LAN devices.  
Prod. no. 98.76784.00-0000



### Ceiling radar

With movement detector for  
early opening in the direction  
of passage.  
Prod. no. 98.73226.00-0000



### ESD

Portable measuring instrument  
and shoe test electrode.  
Prod. no. 98.74210.95-0000



### Base support

Left set  
Prod. no. 23.06939.95-0000  
Right set  
Prod. no. 23.06940.95-0000

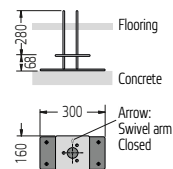

### Assembly plate

For Galaxyport use at a variety of locations,  
for additional systems at major events, etc.  
Prod. no. 23.84565.95-0000  
Design and size on request

<sup>1)</sup> WENI control web server accessories  
Prod. no. 98.76287.00-0000  
Network card for attachment on  
the WEAC 2 control circuit board



Patch cables: 5 m Prod. no. 98.74362.00-0000  
15 m Prod. no. 98.74364.00-0000  
RJ45 UTP LAN adapter for patch cables Prod. no. 98.74510.00-0000

# 02.02 eGate®

Modern entrance and exit systems

- > Attractive design with many functions
- > First-rate materials: aluminium, stainless steel and toughened safety glass
- > Attractive combinations of colour and finish



Design pending

DOUBLE EGATE



DOUBLE EGATE  
with exit section



# 02.02 eGate®

**eGate entrance and exit systems.** Cutting-edge technology for regulating the flow of people at entrances or exits. Wheelchair-accessible passage with variable passage widths.

## Design

Fully enclosed aluminium uprights, stainless steel drive unit. Toughened safety glass swivel arms. Integrated PC interface for data exchange. Programmable WEAC control.

## Function

Opening signal in direction of entry and exit using potential-free contact or network command, e.g. card reader, button, operating panel, radar and ESD measurement devices. Barrier manipulation alarm with automatic barrier return.



## Optional equipment

Integrated radar movement detector, LED signal on the toughened safety glass swivel arm, inscription on swivel arms, climb-over and crawl-under alarm, unauthorised access alarm, connection to central fire alarm system, WEB control panel.

## Accessories

Control program for external PC, control panel, external release button, holders, emergency OPEN switch, power supply from the ceiling, base support set, entry and exit section on the system, swivel range monitoring, integratable guidance elements.

**Radio remote control** for controlling the system. Individual release in direction of passage or exit, continuous release.



**Optional:** Individually illuminated toughened safety glass swivel arms. Power supply from the ceiling. Operating panel for manual opening.



| eGate   | Double system    | Single system, left-opening | Single system, right-opening |
|---|------------------|-----------------------------|------------------------------|
| Consists of:<br>- eGate upright, opening to left and/or right<br>- Electromotor drive unit<br>- Adjustable motor speed<br>- Software monitoring<br>- Interface with the reader: potential-free contacts<br>Please order the swivel arm(s) separately.<br>Swivel arm(s) freely rotatable when not supplied with power. |                  |                             |                              |
| <b>Surface</b>  | <b>Prod. no.</b> | <b>Prod. no.</b>            | <b>Prod. no.</b>             |
| Stainless steel   | 23.31887.09-0001 | 23.31435.09-0001            | 23.31661.09-0001             |
| High gloss chrome-plated  | 23.31887.10-0001 | 23.31435.10-0001            | 23.31661.10-0001             |
| Plastic powder coating  | 23.31887.73-0001 | 23.31435.73-0001            | 23.31661.73-0001             |

Standard colours for aluminium uprights:  
 Anthracite grey RAL7016  
 Metallic anthracite 7097

## 02.02 eGate®

### Technical information

#### Functions

After release by the network or a potential-free closing contact (RFID, radar, control panel), the swivel arm(s) open in the direction of passage. After the adjustable opening period has expired, the swivel arm(s) close fully again. The integrated sensors monitor passage both when the arms are open and when they are closed. Attempted manipulation and unauthorised access are prevented and trigger an alarm.

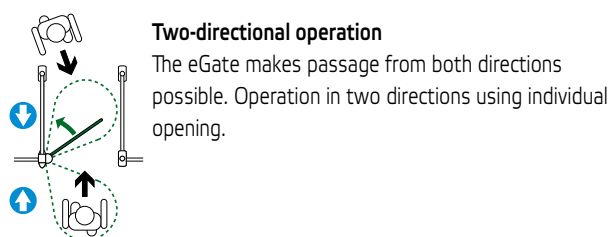

#### Two-directional operation

The eGate makes passage from both directions possible. Operation in two directions using individual opening.

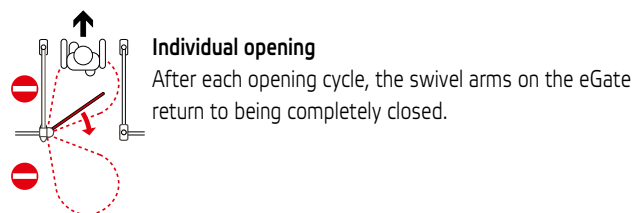

#### Individual opening

After each opening cycle, the swivel arms on the eGate return to being completely closed.

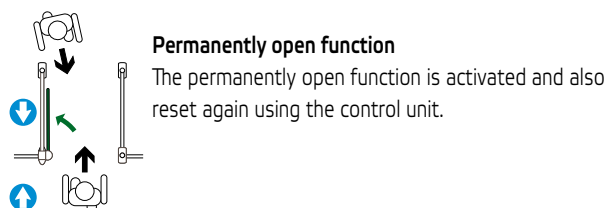

#### Permanently open function

The permanently open function is activated and also reset again using the control unit.

#### Monitoring sensor (optional)

Using 2D technology, the recording sensor system supplies precise data to the gate for monitoring the flow of people in the passage area (entry and exit). All attempts at manipulation and instances of unauthorised access are recognised and indicated.

#### Climb-over alarm (optional)

Only possible with a monitoring sensor. An alarm sounds in case of an attempt to climb over the swivel arm.

#### Crawl-under alarm

An alarm sounds in case of an attempt to crawl under the swivel arm.

#### Swivel arm manipulation

If one of the swivel arms is pushed on, held in place, or its movement is influenced, an alarm signal sounds. The swivel arms then automatically return to the home position.

#### Peripheral release devices (optional)

Card readers, biometric scanners, emergency buttons, control panel, WEB browser, radio remote control; additional devices on request (where possible, the peripheral device can be integrated into the housing).

#### Emergency exit

In the event of an emergency, the swivel arms can be opened in both directions. They can be swivelled freely when not supplied with power, and are reset automatically when the power is switched back on.

#### Fire alarm contact

Break contact connection to central fire alarm system. Automatic opening to allow wheelchair accessible passage.

#### Alarm/silent alarm

In the event of swivel arm manipulation, individuals climbing over or crawling under, unauthorised access and panic opening, etc.

#### Acoustic notifications

Alarms and voice announcements can be played as an MP3.

#### Operating status indicator

Toughened safety glass swivel arms, which can also be illuminated, indicate the eGate operating status.

| LED status indicator             | Toughened safety glass swivel arm |
|----------------------------------|-----------------------------------|
| Release                          | Green                             |
| Alarm/Manipulation/Panic opening | Red                               |
| Standby                          | Blue                              |

# 02.02 eGate®

## Technical specifications



### Material/surface

Uprights: Plastic powder-coated aluminium. Drive unit: Polished stainless steel, chrome-plated or plastic powder-coated.

Barrier elements: Toughened safety glass.

### Drive

Electromotor swivel unit – low maintenance, backlash-free, long service life. Adjustable motor speeds, freely rotatable when not supplied with power.

### Sensor system

Light barriers, radar and ceiling sensors.

### Passage rate

For one-time opening, up to 15 people per minute (depending on the process).

### Interfaces, connecting devices

Predefined release cables, potential-free contacts and network connection for clear and easy wiring of peripheral devices such as card readers, biometric scanners, emergency buttons, the control panel, etc.

### Toughened safety glass swivel arms

Made of 8 mm single-plate safety glass. Sizes and passage widths as specified in the table. Bespoke heights/widths available on request. Optional: Inscription, e.g. a company logo.

| Passage width in mm                 | Standard swivel arms height x width (mm) |     |      |     | Single system |      |      |      | Double system |  |  |  |
|-------------------------------------|--|-----|------|-----|---------------|------|------|------|---------------|--|--|--|
|                                     | 714                                      | 884 | 1014 | 892 | 1174          | 1434 | 1774 | 2034 |               |  |  |  |
| Tube height 300 x                   | 680                                      | 850 | 980  | 410 | 550           | 680  | 850  | 980  |               |  |  |  |
| Toughened safety glass height 300 x | 680                                      | 850 | 980  | 410 | 550           | 680  | 850  | 980  |               |  |  |  |

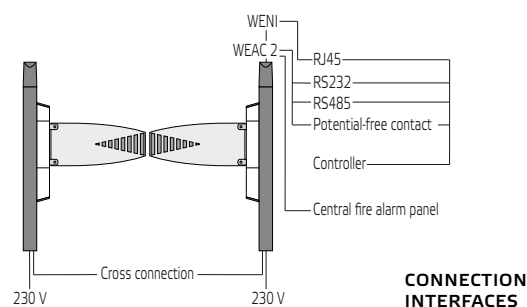

CONNECTION INTERFACES

| eGate                     | Single system   | Double system         |
|---------------------------|-----------------|-----------------------|
| Electricity supply        | 100-240 V       | 100-240 V             |
| Rated frequency           | 50/60 Hz        | 50/60 Hz              |
| Power consumption         | max. 60 W       | max. 60 W per upright |
| Rated current             | max. 0.64 A     | max. 0.64 A           |
| Recommended mains fuse    | 10 AT           | 10 AT                 |
| Protection class          | I               | I                     |
| Degree of protection      | IP20            | IP20                  |
| Ambient temperature       | +10°C to + 50°C | +10°C to + 50°C       |
| Weight without swivel arm | 30 kg           | 2 x 30 kg             |

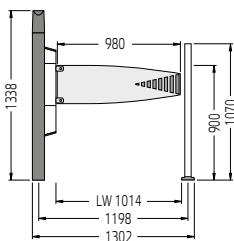

SINGLE eGATE

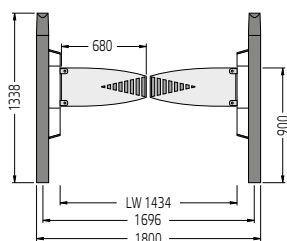

DOUBLE eGATE

### Installation surfaces

Concrete foundation C25/30 or ground with a minimum compressive strength of 25N/mm<sup>2</sup>, flatness tolerance of +/- 5mm

# 02.03 Technoport®

Entrance and exit system with versatile applications

- > *Tried and tested on industrial and production sites*
- > *Robust and compact*
- > *Stainless steel design*



**DOUBLE TECHNOPORT**  
with tubing barriers and signs

YouTube

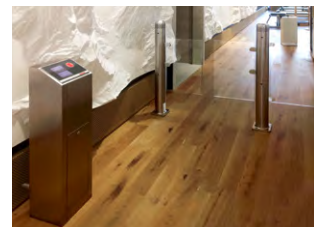

**TOUGHENED SAFETY GLASS**  
SWIVEL ARMS, printed



## 02.03 Technoport®

■ **Technoport entrance and exit systems.** Cutting-edge technology for regulating the flow of people at entrances or exits. Wheelchair-accessible passage with variable passage widths.

### Design

Stainless steel round tube upright and swivel arms, chrome-plated or plastic-coated. Swivel arms with sign. Integrated PC interface for data exchange. Programmable WEAC control.

### Function

Opening signal in direction of entry and exit using potential-free contact or network command, e.g. card reader, button, operating panel, radar and ESD measurement devices. Barrier manipulation alarm with automatic barrier return.



### Optional equipment

Integrated radar movement detector, toughened safety glass swivel arms, tall swivel arms, climb-over and crawl-under alarm, unauthorised access alarm, connection to the central fire alarm system, WEB control panel.

### Accessories

Control program for external PC, radio remote control, control panel, external release button, emergency OPEN switch, ceiling connection tube for wiring, entry and exit section on the system, swivel range monitoring, integrated guidance elements.

**Radio remote control** for controlling the system. Individual release in direction of passage or exit, continuous release.



**Optional:** Radar control, customised swivel arms, visual alarm in light dome, function display module, power supply from the ceiling.



| Technoport   |                  |                             |                              |
|--|------------------|-----------------------------|------------------------------|
|  | Double system    | Single system, left-opening | Single system, right-opening |
| Consists of:<br>- Technoport upright opening to left and/or right<br>Please order swivel arms separately.<br>The swivel arm can be turned freely when not supplied with power. |                  |                             |                              |
| <b>Surface</b>   | <b>Prod. no.</b> | <b>Prod. no.</b>            | <b>Prod. no.</b>             |
| Stainless steel  | 23.53224.09      | 23.72104.09                 | 23.72105.09                  |
| High gloss chrome-plated   | 23.53224.10      | 23.72104.10                 | 23.72105.10                  |
| Plastic powder coating   | 23.53224.73      | 23.72104.73                 | 23.72105.73                  |

Colours for plastic powder-coated systems available on request.

## 02.03 Technoport®

### Technical information

#### Functions

After release by the network or a potential-free closing contact, the swivel arm(s) open in the direction of passage. After the opening period has expired, the swivel arm(s) close fully again. The integrated sensors monitor passage both when the arms are open and when they are closed. Attempted manipulation and unauthorised access are prevented and trigger an alarm.

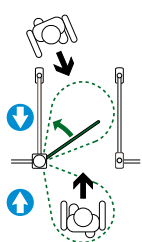

#### Two-directional operation

The Technoport allows for passage from two directions. Operation in two directions using individual opening

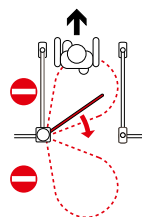

#### Individual opening

After each opening cycle, the swivel arms on the Technoport return to being completely closed.

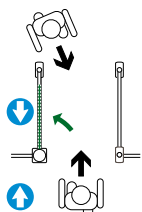

#### Permanently open function

The permanently open function is activated and also reset again using the control unit.

#### Operating status indicator

Illuminated toughened safety glass swivel arms are used as an operating status indicator (optional).

| LED status indicator             | Toughened safety glass swivel arm |
|----------------------------------|-----------------------------------|
| Release                          | Green                             |
| Alarm/Manipulation/Panic opening | Red                               |
| Standby                          | Blue                              |

#### Monitoring sensor (optional)

Using 2D technology, the recording sensor system supplies precise data to the Technoport for monitoring the flow of people in the passage area (entry and exit). All attempts at manipulation and instances of unauthorised access are recognised and indicated.

#### Climb-over alarm (optional)

Only possible with a monitoring sensor. An alarm sounds in case of an attempt to climb over the swivel arm.

#### Crawl-under alarm

Only possible with a monitoring sensor. An alarm sounds in case of an attempt to crawl under the swivel arm.

#### Swivel arm manipulation

If one of the swivel arms is pressed on, held in place, or its movement is influenced, an alarm signal sounds. The swivel arms then automatically return to the home position.

#### Peripheral release devices (optional)

Card readers, biometric scanners, emergency buttons, control panel, WEB browser, radio remote control; additional devices on request (where possible, the peripheral device can be integrated into the housing).



#### Emergency exit

In the event of an emergency, the swivel arms can be opened in both directions. They can be swivelled freely when not supplied with power, and are reset automatically when the power is switched back on.



#### Fire alarm contact

Break contact connection to central fire alarm system. Automatic opening to allow wheelchair accessible passage.

#### Alarm/silent alarm

In the event of swivel arm manipulation, individuals climbing over or crawling under, unauthorised access and panic opening, etc.

#### Acoustic notifications

Alarms and voice announcements can be played as an MP3.

# 02.03 Technoport®

## Technical specifications



### Material/surface

Uprights: Polished stainless steel, high-gloss chrome-plated, or plastic powder-coated in your preferred RAL colour.

Swivel arms: Polished stainless steel, high-gloss chrome-plated, colour plastic powder-coated, or single-pane safety glass

### Drive

Electromotor swivel unit – low maintenance, backlash-free, long service life. Adjustable motor speeds, freely rotatable when not supplied with power.

### Sensor system

Light barriers, radar and ceiling sensors.

### Passage rate

For one-time opening, up to 15 people per minute (depending on the process).

### Interfaces, connecting devices

Predefined release cables, potential-free contacts and network connection for clear and easy wiring of peripheral devices such as card readers, biometric scanners, emergency buttons, the control panel, etc.

### Swivel arms

Made from steel tube with sign or 8 mm single-pane safety glass. Sizes and passage widths as specified in the table. Bespoke heights/widths available on request.

| Passage width in mm                 | Standard swivel arms height x width (mm) |     |      |     |               |      |      |      |
|-------------------------------------|--|-----|------|-----|---------------|------|------|------|
|                                     | Single system                            |     |      |     | Double system |      |      |      |
| Tube height 300 x                   | 714                                      | 884 | 1014 | 892 | 1174          | 1434 | 1774 | 2034 |
| Toughened safety glass height 300 x | 680                                      | 850 | 980  | 410 | 550           | 680  | 850  | 980  |

Swivel arm is made from steel tube, height 750 mm, extendible from 630 to 930 mm on request.

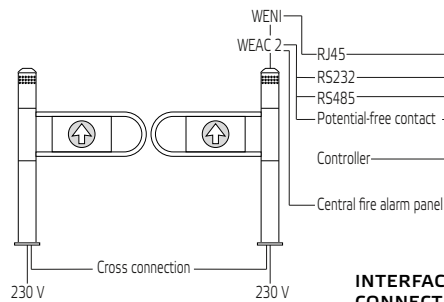

### INTERFACES CONNECTIONS

| Technoport                        | Single system  | Double system         |
|-----------------------------------|----------------|-----------------------|
| Electricity supply                | 100-240 V      | 100-240 V             |
| Rated frequency                   | 50/60 Hz       | 50/60 Hz              |
| Power consumption                 | max. 60 W      | max. 60 W per upright |
| Rated current                     | max. 0.64 A    | max. 0.64 A           |
| Recommended mains fuse            | 10 A T         | 10 A T                |
| Protection class                  | I              | I                     |
| Degree of protection              | IP20           | IP20                  |
| Ambient temperature               | +10°C to +50°C | +10°C to +50°C        |
| Upright weight without swivel arm | 45 kg          | 45 kg per upright     |

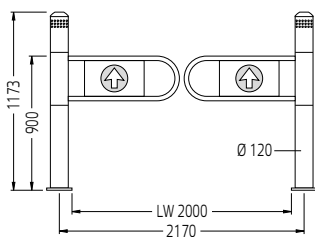

DOUBLE TECHNOPORT

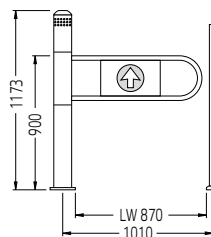

SINGLE TECHNOPORT

### Installation surfaces

Concrete foundation C25/30 or ground with a minimum compressive strength of 25N/mm<sup>2</sup>, flatness tolerance of +/- 5mm

# 02.04 eGate<sup>®</sup> Checkout

The MADE\_BY\_WANZL solution

- > Security for your customers and offices
- > Easy operation in two directions
- > Wall mounting for when space is limited

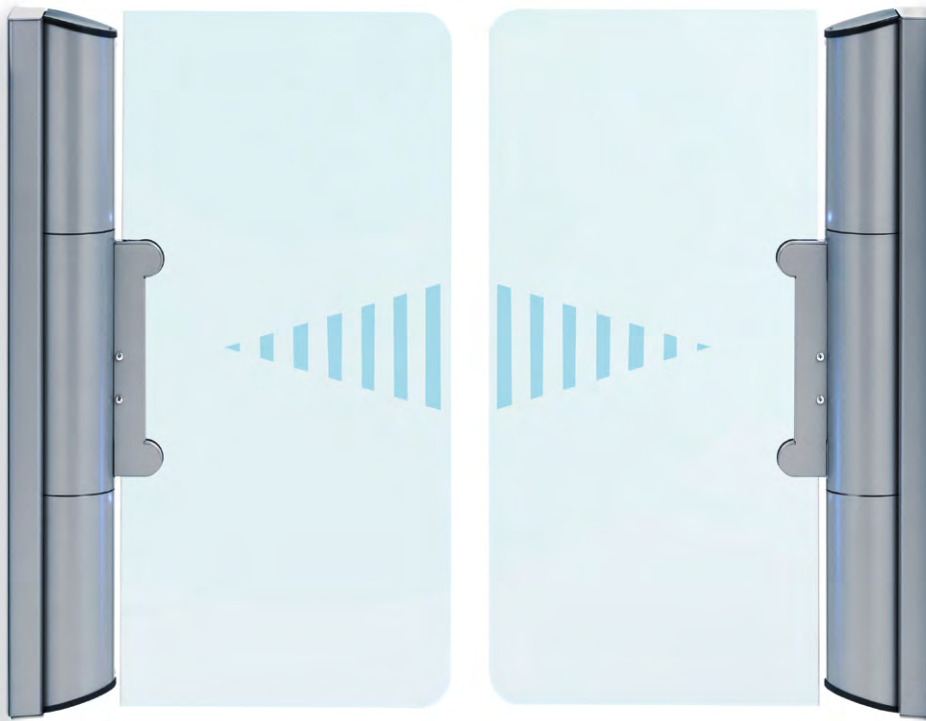

**eGATE CHECKOUT**  
Standby  
with tall swivel arms

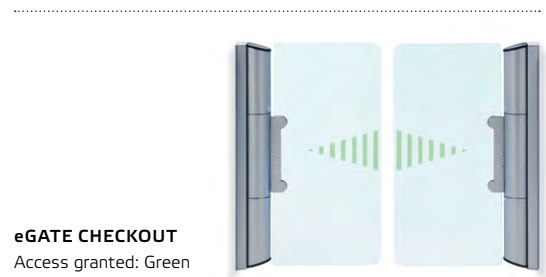

**eGATE CHECKOUT**  
Access granted: Green



**eGATE CHECKOUT**  
Access denied: Red



## 02.04 eGate® Checkout

■ **eGate Checkout systems** have many features as standard, for your customers' security as well as your own. They ensure a smooth process in entry and exit areas.

### Design

Fully enclosed sheet steel housing, stainless steel drive unit. Individually illuminated toughened safety glass swivel arms. Integrated PC interface for data exchange. Programmable WEAC control.

### Function

Opening signal in direction of entry and exit using potential-free contact or network command, e.g. card reader, button, operating panel, radar and ESD measurement devices. Barrier manipulation alarm with automatic barrier return.



### Accessories

- LED swivel arm
- Remote control
- Monitoring sensor
- PC control unit

- Radio remote control
- External release button
- Web server
- Fire alarm contact connection terminal

**Radio remote control** for controlling the system. Individual release in direction of passage or exit, continuous release.



**Optional:** Individually labelled toughened safety glass swivel arms. Operating panel for manual opening.



### eGate Checkout

Consists of:  
Housing with drive unit  
Swivel arms (order separately)  
The swivel arms can be swivelled freely when not supplied with power.

### Double system

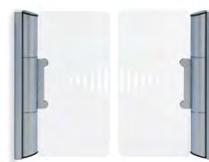



### Surface

- Stainless steel
- High gloss chrome-plated
- Plastic powder coating

### Prod. no.

- 23.84452.09-0000
- 23.84452.10-0000
- 23.84452.73-0000

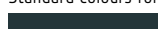
Standard colours for housing:

-  Anthracite grey RAL7016
-  Metallic anthracite 7097

## 02.04 eGate® Checkout

### Technical information

#### Functions

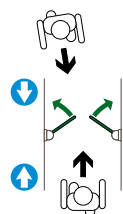

##### Two-directional operation

The eGate Checkout makes passage from both directions possible. Operation in two directions using individual opening.

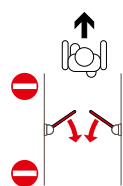

##### Individual opening

After each opening cycle, the swivel arms on the eGate Checkout return to being completely closed.

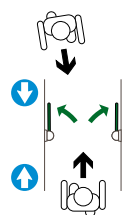

##### Permanently open function

The permanently open function is activated and also reset again using the control unit.

#### Operating status indicator

Toughened safety glass swivel arms, which can also be illuminated, indicate the eGate Checkout operating status.

| LED status indicator             |                                   |
|----------------------------------|-----------------------------------|
|                                  | Toughened safety glass swivel arm |
| Release                          | Green                             |
| Alarm/Manipulation/Panic opening | Red                               |
| Standby                          | Blue                              |

#### Monitoring sensor (optional)

Using 2D technology, the recording sensor system supplies precise data to the gate for monitoring the flow of people in the passage area (entry and exit). All attempts at manipulation and instances of unauthorised access are recognised and indicated.

#### Climb-over alarm (optional)

Only possible with a monitoring sensor. An alarm sounds in case of an attempt to climb over the swivel arm.

#### Swivel arm manipulation

If one of the swivel arms is pushed on, held in place, or its movement is influenced, an alarm signal sounds. The swivel arms automatically return to the home position.

#### Peripheral release devices (optional)

Card readers, biometric scanners, emergency buttons, control panel, WEB browser, radio remote control; additional devices on request (where possible, the peripheral device can be integrated into the housing).



#### Emergency exit

In the event of an emergency, the swivel arms can be opened in both directions. They can be swivelled freely when not supplied with power, and are reset automatically when the power is switched back on.



#### Fire alarm contact

Break contact connection to central fire alarm system. Automatic opening to allow wheelchair accessible passage.

#### Alarm/silent alarm

In the event of swivel arm manipulation, individuals climbing over or crawling under, unauthorised access and panic opening, etc.

#### Acoustic notifications

Alarms and voice announcements can be played as an MP3.

# 02.04 eGate® Checkout

## Technical specifications

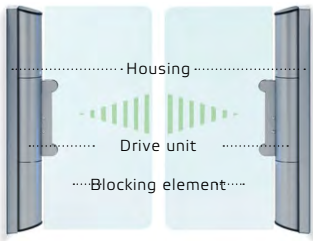

**Surface**  
 Housing: Plastic powder-coated.  
 Drive unit: Polished stainless steel, chrome-plated or plastic powder-coated.  
 Barrier elements: Toughened safety glass.

**Swivel arms**  
 Made from 8 mm single-pane safety glass, width: minimum 250 mm to maximum 450 mm Sizes and passage widths as specified in the table.

**Sensor system**  
 Light barriers, radar and ceiling sensors.

**Passage rate**  
 For one-time opening, up to 15 people per minute (depending on the process).

**Interfaces, connecting devices**  
 Predefined release cables, potential-free contacts and network connection for clear and easy wiring of peripheral devices such as card readers, biometric scanners, emergency buttons, the control panel, etc.

| Standard swivel arms height x width (mm) |                  |                  |
|--|------------------|------------------|
| Passage width in mm                      | Double eGate     |                  |
|  |                  | 550              |
| Toughened safety glass height 870 x      | 250 (min. width) | 450 (max. width) |

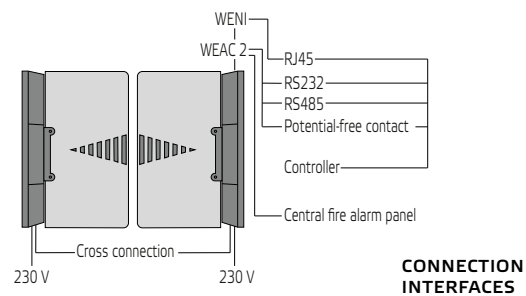

**CONNECTION INTERFACES**

| eGate Checkout            | Double eGate Checkout |
|---------------------------|-----------------------|
| Electricity supply        | 100-240 V             |
| Rated frequency           | 50/60 Hz              |
| Power consumption         | 60 W per upright      |
| Rated current             | max. 0.64 A           |
| Recommended mains fuse    | 10 A T                |
| Protection class          | I                     |
| Degree of protection      | IP20                  |
| Ambient temperature       | +5° C to + 50° C      |
| Weight without swivel arm | 2 x 90 kg             |

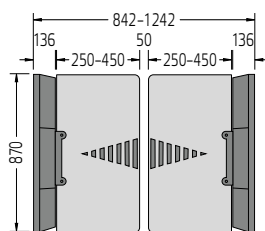

**DOUBLE eGATE CHECKOUT**

## 02.02-02.04 eGate®, Technoport®, eGate® Checkout

### Accessories

#### Customised swivel arms

Printed or sand-blasted with your company logo, welcome or information text, etc.  
On request



#### Operating status indicator\*

The printed or sand-blasted logo is illuminated with a coloured LED and indicates the following to the visitor: BLUE – system ready, GREEN – authorisation successful, passage is enabled, or RED – no passage due to failed or incorrect authorisation, or manipulation.  
Prod. no. 98.76413.00-0000

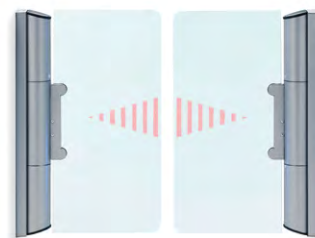
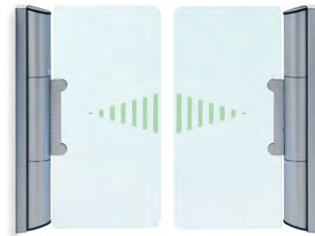

#### Reader units

A wide range of reader systems can be installed to review access authorisation:

- Palm vein scanners
- Facial recognition
- Fingerprint
- Iris recognition
- RFID or NFC
- Barcode or QR code
- "Swallowing" card reader



#### WEB control panel.

A smartphone app, WLAN router and web server<sup>1)</sup> are required for this.  
Prod. no. 23.88171.95-9016



#### Control program for external PC

Software for operating the systems, to be installed on a PC that is already in place on-site.  
Prod. no. 23.79480.00-0000  
Required: Web server<sup>1)</sup>.

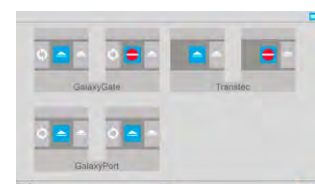

#### Galaxy box

"Swallowing" card reader, standard version with info screen.  
Prod. no. 23.35528.09-0000  
For detailed information, see section titled Accessories: Galaxy box



#### Touchscreen PC as a control panel

Standalone touchscreen PC for operating the systems.  
Prod. no. 98.76806.00-0000  
Required: Web server<sup>1)</sup>.



#### Control Panel

For controlling the system.  
One-time and permanent opening.  
With connection cable  
5 m Prod. no. 98.76762.00-0000  
10 m Prod. no. 98.76763.00-0000  
25 m Prod. no. 98.76764.00-0000



\* Not Technoport

## 02.02-02.04 eGate®, Technoport®, eGate® Checkout

### Radio remote control

For controlling one or multiple systems. Individual release in direction of passage or exit, continuous release.  
Prod. no. 98.73693.00-0000



For manual opening:

**Button**, 5 m cable

Prod. no. 23.79249.95-0000

**Mushroom button**, 5 m cable

Prod. no. 98.73449.00-0000

**Foot-operated switch**, 5 m cable

Prod. no. 98.72775.00-0000



### Emergency open switch

Following operation, passage in the exit direction opens automatically.  
Prod. no. 98.76947.95-0000



### External emergency open button

Following operation, passage in the exit direction is automatically opened.  
Prod. no. 98.74366.00-0000



### Ceiling connection tube

Simple wiring from above.  
Prod. no. 23.27237.10-0000



### Ceiling radar

With movement detector for early opening in the direction of passage.  
Prod. no. 98.73226.00-0000



### Flashbulb

with mox plug. Optical signal, e.g. in the event of arm manipulation.  
Prod. no. 98.73452.00-0000



### ESD

Portable measuring instrument and shoe test electrode.  
Prod. no. 98.74210.95-0000



### WLAN router

Remote control via mobile devices.  
Prod. no. 23.88171.95-9016



### Switch port

Connection of several LAN devices.  
Prod. no. 98.76784.00-0000



<sup>1)</sup> WENI control web server accessories  
Prod. no. 98.76287.00-0000  
Network card for attachment on the  
WEAC 2 control circuit board



Patch cables: 5 m Prod. no. 98.74362.00-0000  
15 m Prod. no. 98.74364.00-0000  
RJ45 UTP LAN adapter for patch cables Prod. no. 98.74510.00-0000

# 02.05 Goods transportation gates

Mechanical, passage width up to 1350 mm

- > For forklifts or lift trucks with Euro pallets
- > Designs with one or two gates
- > High or low design



**GOODS TRANSPORTATION GATES**  
opening to the left

**Area of application:** Lockable gates for transporting goods. Variable gateway widths – extendible swivel arms and assembly as a double system allows Euro pallets to be transported through the gateway.

## Design

Steel tube upright with metal base plate and base plate cover. Flanged design for assembly on the wall, partition, etc. Swivel arms in different designs made from steel tube with a sign printed on both sides. Finish: High-gloss chrome plating, coloured plastic powder coating\* or stainless steel.

## Accessories

- Different swivel arm sizes
- Sign with emergency exit symbol
- Sign for ESD area

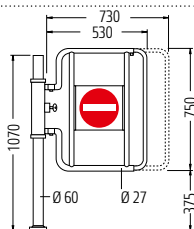

## Function

Once the goods transportation gate has been unlocked, the barrier can be swung in either direction and locks in the 90° position.



| Goods transport gates  |                                |                                |
|--|--------------------------------|--------------------------------|
| High design  | With upright                   | With flange                    |
| <ul style="list-style-type: none"> <li>- High-gloss chrome-plated</li> <li>- Other finishes available on request</li> <li>- Extendible swivel arms, 530-730 mm</li> <li>- Sign with no entry symbol, front and back</li> </ul> |                                |                                |
| Panic function on both sides   | Prod. no.<br>23.02 735.10-V003 | Prod. no.<br>23.02 747.10-V001 |

**GOODS TRANSPORT GATES**  
Double system

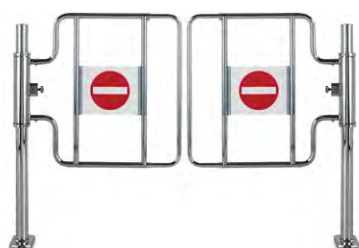

**Angle adapter**  
For installation in smaller areas.  
Prod. no. 23.08415.10

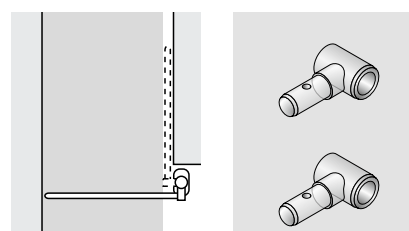

\* Different colours available upon request.

# 02.06 Swivel gates

Mechanically controlled passage

- > Mechanical, opens to one or both sides
- > Flexible passage widths
- > Panic function as standard



**SWIVEL DOORS**  
open to left

■ **Area of application:** Easy segregation of non-public areas, e.g. at the access point to an information desk. Wheelchair-accessible passage. Adjustment of passage width to structural conditions.

## Design

Steel tube upright with metal base plate and base plate cover. Steel tube swivel arms. Hydraulic door closer, adjustable closing speed. Plastic sign, printed on both sides. Finish: High-gloss chrome plating, coloured plastic powder coating\* or stainless steel.

## Accessories

Signs printed on both sides with no entry symbols, or with an arrow and emergency exit symbol.

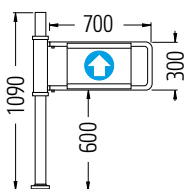

## Functions

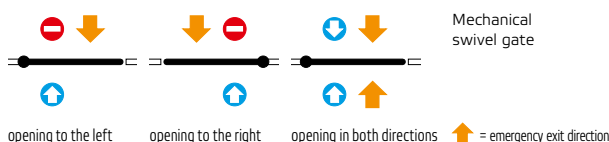

| Swivel gates  | Mechanical          |                      |                            |
|---|---------------------|----------------------|----------------------------|
| Direction of opening  | opening to the left | opening to the right | opening in both directions |
| Swivel gate with swivel arms and sign printed on both sides |                     |                      |                            |
| Design  | Prod. no.           | Prod. no.            | Prod. no.                  |
| Standard version  | 23.08723.10-V001    | 23.08723.10-V004     | 23.08723.10-V007           |
| Accessories for replacement equipment                       |                     |                      |                            |
| 400 x 237 mm sign, printed on both sides                    |                     |                      |                            |
| Front  / rear   | 00.12746.07         | 00.12746.07          | 00.12746.07                |
| Front  / rear   | 00.12714.07         | 00.12714.07          | 00.12714.07                |
| Front  / rear   | 00.39979.07         | 00.39979.07          | 00.39979.07                |
| Plastic profile for assembly                                | 00.12713.07         | 00.12713.07          | 00.12713.07                |

\* Different colours available upon request.

# 02.07 Example Installations

Entry and exit systems – reliable access control solutions

- > Sport, fitness and leisure facilities
- > Public institutions, airports, trade fairs and exhibitions
- > Personnel access points for companies and offices

Fig. 1

**DOUBLE TECHNOPORT**

Customised toughened safety glass swivel arms, partition made of toughened safety glass, card reader

Fig. 2

**eGATE CHECKOUT**

coloured plastic powder-coated

Fig. 3

**TECHNOPORT**

Customised toughened safety glass swivel arm, EasyGo, stainless steel partition with toughened safety glass, coloured plastic powder-coated surfaces

Fig. 4

**eGATE**

Toughened safety glass swivel arms, two Sirio turnstiles, U profiles for wiring in the floor, stainless steel partition with toughened safety glass

Fig. 5

**TWO DOUBLE TECHNOPORTS**

With exit section, swivel arms made from stainless steel with signs





## 02.07 Example Installations

■ For a smooth-running operation, Wanzl entry and exit systems are the way forward! They bring together a high level of functionality and reliability with attractive design.

Fig. 1

**DOUBLE TECHNOPORT**

Customised toughened safety glass swivel arms, partition made of toughened safety glass, card reader

Fig. 2

**TWO eGATES**

Illuminated toughened safety glass swivel arms, stainless steel partition with toughened safety glass, card reader

Fig. 3

**DOUBLE TECHNOPORT**

Toughened safety glass swivel arms, stainless steel partition with toughened safety glass, card reader

Fig. 4

**eGATE**

With exit section, toughened safety glass swivel arm, Classic partition

Fig. 5

**DOUBLE TECHNOPORT**

Swivel arms in custom design made from stainless steel

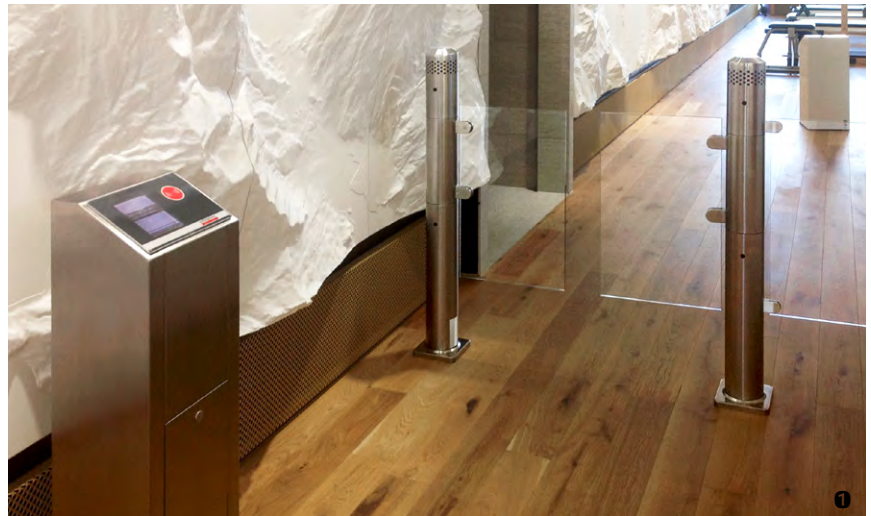
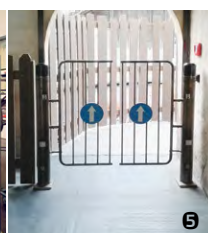

Fig. 6

**DOUBLE eGATE**

Illuminated toughened safety glass swivel arms, ESD-controlled



# 03 Product overview

## 03.01 Sirio®



01 2-ARM



01 3-ARM

## 03.02 EasyGo



02 2-ARM



02 3-ARM



02 WALL MOUNTING

## 03.03 Portec



03 3-ARM

## 03.04 Transtec



04 VERTICAL TURNSTILE

## 03.05 Low Atlas



05 VERTICAL TURNSTILE

## 03.06 Atlas



06 PORTAL TURNSTILE

## 03.07 Example installations



08 ENTRY AND EXIT SOLUTIONS

# 03 Turnstiles



# 03.01 Sirio

*Elegant motor-driven turnstile*

- > *Ideal in architecturally sophisticated settings*
- > *In form-fitting stainless steel housing*
- > *Contactless start, available with 2 or 3 arms*



SIRIO WITH 2 ARMS

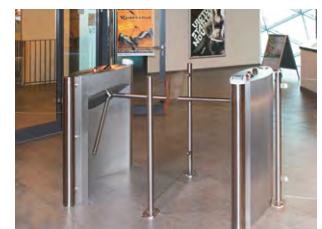

# 03.01 Sirio

■ **Sirio turnstiles guarantee the greatest possible level of comfort in the passage of individuals.** Reliable individual entry separation in a wide range of entrance areas. Release using card reader, coin operation, control panel, ticketing system or to custom requirements. The elegant guidance elements are in keeping with the attractive design of the Sirio turnstiles and aid reliable entry separation.

## Design

Stainless steel housing, side uprights and turnstile mechanism. Tried and tested low-maintenance mechanism. Programmable control, can be adapted to suit individual customer requirements. Can be integrated into the building management system. Interface for security products and time recording systems.

## Function

Release using standard card reader, coin operation, ticket machine, control panel, ticketing system or building control system.



## Optional equipment

Climb-over and crawl-under protection, light sensors to start barrier arm rotation contactlessly.



## Accessories

Control panels, emergency OPEN switch, LED release signal, attachment board for additional connection options, holders, base support set, guidance elements, Galaxyport, mechanical or electrical gates for wheelchair-accessible passage.

**Control panel** For any additional, manual releases, the display shows operation conditions, counter status, error messages and warnings. Connection of up to 2 turnstiles. Adjustment of control parameters.

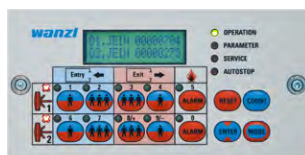

**Optional equipment:** LED release signal lighting, climb-over/crawl-under protection with acoustic alarm, sensors for non-contact rotation, emergency button.



| Motor-driven Sirio turnstile  |   |   |
|---|---|---|
|   | 2-arm   | 3-arm   |
| <p>Consists of:</p> <ul style="list-style-type: none"> <li>- Housing, turnstile arms</li> <li>- Electromotor swivel unit</li> <li>- 120° and 240° rotation</li> <li>- Interface with the reader: potential-free contacts</li> <li>- Manufacturing standard: DIN-ISO 9001</li> </ul> |   |   |
| <p><b>Surface</b><br/>Stainless steel</p>   | <p><b>Prod. no.</b><br/>23.50004.09 V001</p>  | <p><b>Prod. no.</b><br/>23.50003.09 V001</p>  |
| <p>The turnstile can be rotated freely when the power supply is disconnected.</p>   | <p>The turnstile rotates either by 120° or 240° during a cycle, depending on its position. In addition, the turnstile can be motor-driven into wheelchair-accessible/alarm position. Passage is then enabled.</p> | <p>A rotary movement of 120° is initiated by the motor. In the event of an alarm the turnstile can be freely rotated.</p> |

## 03.02 EasyGo

*Motor-driven variable turnstile*

- > *Space-saving solution for assembly on walls or uprights*
- > *In compact stainless steel housing*
- > *Available with 2 or 3 arms*



EASYGO WITH 2 ARMS

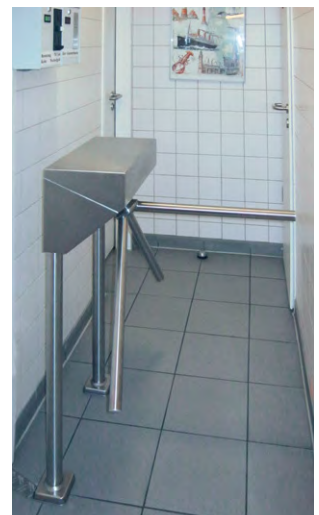

# 03.02 EasyGo

■ **EasyGo turnstiles**, compact design and variable usage options. Efficient in use for many years, in a huge variety of situations. For reliable individual entry separation with minimal space requirements. Release using card reader, coin operation, operating panel, ticketing system or to custom requirements.

## Design

Fully enclosed stainless steel housing and turnstile mechanism. Low maintenance mechanism. Programmable control, can be adapted to suit individual customer requirements. Can be integrated into the building management system. Interface for security products and time recording systems. Can be rotated freely when not supplied with power.

## Function

System integration: Access can be combined with ESD technology.



## Optional equipment

Climb-over and crawl-under protection, light sensors to start barrier arm rotation contactlessly.



## Accessories

Control panels, emergency OPEN switch, LED release signal, attachment board for additional connection options, holders, base support set, guidance elements, Galaxyport, mechanical or electrical gates for wheelchair-accessible passage.

**Control panel** For any additional, manual releases, the display shows operation conditions, counter status, error messages and warnings. Connection of up to two turnstiles. Adjustment of control parameters.

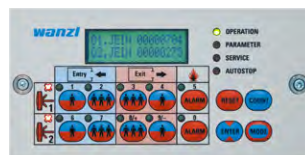

**Optional equipment:** LED release signal lighting, crawl-under/climb-over protection with acoustic alarm, sensors for non-contact rotation, emergency button.



| EasyGo turnstile   | Motor-driven<br>2-arm, both directions   | Motor-driven<br>3-arm, both directions   |
|--|--|--|
| Consists of: <ul style="list-style-type: none"> <li>- Housing, turnstile arms</li> <li>- Electromotor swivel unit</li> <li>- Interface with the reader: potential-free contacts</li> <li>- Manufacturing standard: DIN-ISO 9001</li> </ul> |  |  |
| <b>Assembly</b><br>On uprights<br>With wall bracket  | <b>Prod. no.</b><br>23.00088.09<br>23.00092.09   | <b>Prod. no.</b><br>23.00094.09<br>23.20258.09   |
| The turnstile can be rotated freely when the power supply is disconnected.   | The turnstile rotates either by 120° or 240° during a cycle, depending on its position. In addition, the turnstile can be motor-driven into wheelchair accessible/alarm position. Passage is then enabled. | A rotary movement of 120° is initiated by the motor. In the event of an alarm the turnstile can be freely rotated. |

## 03.01-03.02 Sirio, EasyGo

### Technical information

#### Functions

After release, rotation starts automatically when the barrier arm is touched, or contactlessly. The rotation enables one person access in the direction of travel, while the second arm simultaneously blocks the direction of passage. Attempted manipulation and unauthorised access are prevented and trigger an alarm.

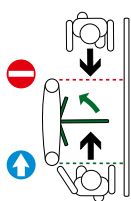

#### Two-directional operation

The Sirio and EasyGo turnstiles enable passage from two directions. If people from both directions would like to pass through simultaneously, the first person to activate the sensors for opening takes precedence.

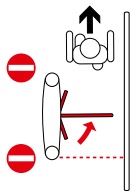

#### Individual opening

After each passage cycle, the turnstile arm again blocks access – only then can the next release for each passage direction take place.

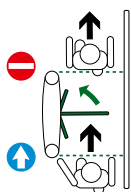

#### Multiple opening

An additional person is able to release the next passage cycle during an ongoing passage cycle. In this process, the turnstile stores up the releases and lets the corresponding number of individuals pass through.

#### Permanently open function

The turnstile can be permanently passed through in the respective direction.

#### Arm movement

- 2-arm technology (1x120° and 1x240° rotation)
- 3-arm technology (3x120° rotation)
- Rotation will stop in the event of arm contact
- Arm manipulation alarm

#### Opposite direction block

After each person, the turnstile arm again blocks passage, and therefore does not permit access from the opposite direction unless permanently open is engaged in the opposite direction.

#### Climb-over alarm (optional)

An alarm sounds if an attempt is made to climb over the turnstile arm.

#### Crawl-under alarm (optional)

An alarm sounds if an attempt is made to crawl under the turnstile arm.

#### Arm manipulation

If the turnstile arm is pushed on, an alarm signal sounds. The arm then automatically returns to the home position.

#### Peripheral release devices (optional)

Various card readers, biometric scanners, emergency button, control panel, control panel with random generator or preselection function, radio remote control, permanently open function, others on request.



#### Escape route

In the event of an emergency, the arms can be opened in both directions. They can be rotated freely when the power supply is disconnected, and reset automatically when the power is switched back on.



#### Fire alarm contact

Break contact connection to central fire alarm system. Automatic opening to allow wheelchair accessible passage.

#### Operating status indicator (optional)

Integrated LED clusters signal the operating status of the turnstile in entry and exit.

| LED status indicator |               |
|----------------------|---------------|
|                      | LED indicator |
| Release              | Green         |
| Standby              | Red           |

#### Acoustic notifications

Alarm sirens.

#### Feedback contact

Following successful passage.



# 03.01-03.02 Sirio, EasyGo

## Technical specifications

### Surface

Sirio: Polished stainless steel.  
 EasyGo: Polished stainless steel or coated in RAL colour of choice.  
 Turnstile arms: Polished stainless steel.

### Drive

Electromotor swivel unit – low maintenance, backlash-free, long service life. Adjustable motor speeds, freely rotatable when power supply is disconnected.

### Sensor system

Light barrier and contact sensor.

### Passage rate

For one-time release up to 25 people/minute (depending on the concept).

### Interface connection of devices

Four configurable connection options in the entry and exit direction, four configurable feedback contacts.

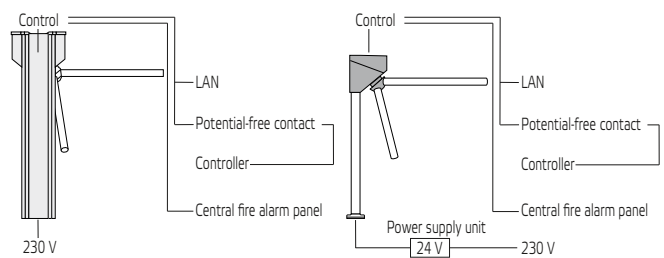

**U PROFILE**  
 for cabling and floor,  
 if there are no empty  
 conduits.

| Turnstiles   | Sirio              | EasyGo             |
|--|--------------------|--------------------|
| Electricity supply                                     | 230 V ~, 50-60 Hz  | 230 V ~, 50-60 Hz  |
| Consumption  | 20 Wh              | 20 Wh              |
| Power consumption                                      | 200 VA             | 200 VA             |
| Rated current  | 0.88 A             | 0.88 A             |
| Protection class                                       | I                  | I                  |
| Protection class for the turnstile/controls/power unit | IP 22              | IP 22              |
| Ambient temperature                                    | - 25° C to + 50° C | - 25° C to + 50° C |
| Weight   | 71 kg              | 45 kg              |

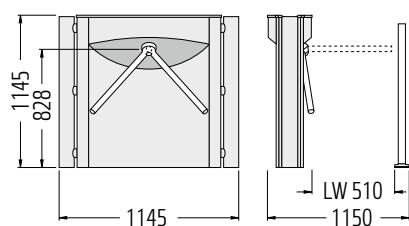

**SIRIO 2 OR 3 ARMS**  
 with guidance element

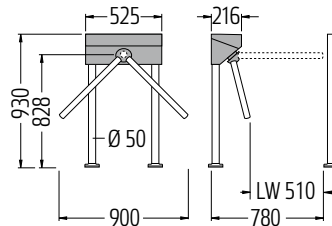

**EASYGO WITH 2 OR 3 ARMS**  
 with guidance element

**Installation surfaces**  
 Concrete foundation C25/30 or  
 ground with a minimum compressive  
 strength of 25N/mm<sup>2</sup>, flatness toler-  
 ance of +/- 5mm

LW = inner clearance/passage width

## 03.03 Portec

*Electro-mechanical turnstile*

- > *Easy and cost-effective separation of individuals*
- > *Attractive combinations of materials and colours*
- > *3 arms*



**PORTEC WITH 3 ARMS**  
Hinged arms



**PORTEC WITH 3 ARMS**  
Folding arms  
with counterpart

# 03.03 Portec

■ **Portec turnstiles for entry and exit.** Reliable turnstiles with electro-mechanical design for safe and dependable individual entry separation for large flows of people.

## Design

Solid stainless steel housing with cast aluminium, arms made from stainless steel. Extremely compact, robust, low-maintenance mechanism. LED function display in direction of entrance and exit, acoustic alarm signal and operating panel as standard.

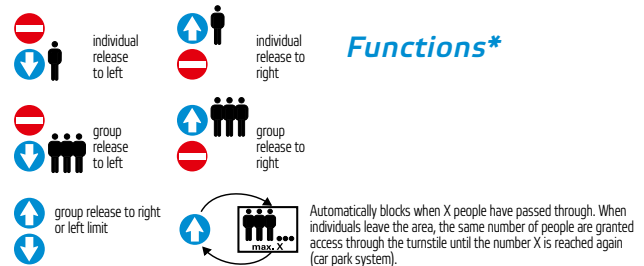

## Optional equipment

Holders for card readers, panic function, emergency button, etc.



## Accessories

Counterpieces or guidance elements, mechanical or electrical gates for wheelchair-accessible passage, Galaxyport.



## Control panel with LCD display.

Function selection: One-time and group release in both directions, pedestrian counting for one-time opening. Connection for card reader and serial interface.



## Panic function

In the event of an emergency the hinged arm design opens for passage in both directions. The acoustic alarm indicates emergency operation.



| Portec   | Electro-mechanical     | Accessories      |   |
|--|------------------------|------------------|---|
|  | EP with panic function | Counterpart      | Guidance elements with acrylic glass panels |
| Consists of:<br>- Housing, turnstile arms<br>- Electromechanical swivel unit<br>- Interface: potential-free contacts<br>- Manufacturing standard: DIN-ISO 9001<br>The turnstile can be rotated freely when power supply is disconnected. |                        |                  |   |
| <b>Surface</b>   | <b>Prod. no.</b>       | <b>Prod. no.</b> | <b>Prod. no.</b>                            |
| High gloss chrome-plated   | 23.73 474.10           | 23.73 539.10     | 23.64 297.10                                |
| Stainless steel  | 23.73 474.09           | 23.73 539.09     | 23.64 297.09                                |
| Plastic powder coating   | 23.73 474.73           | 23.73 539.73     | 23.64 297.73                                |

Standard colours\* for cast aluminium parts:  
 Anthracite grey RAL7016  
 Metallic anthracite 7097

\* Additional RAL colours available on request.

## 03.03 Portec

### Technical information

#### Functions

After release, the turnstile arms can be passed through by pushing. The rotation of the turnstile arms enables one-person access in the direction of travel, while the next arm simultaneously blocks the direction of passage. Attempted manipulation and unauthorised access are prevented and trigger an alarm.

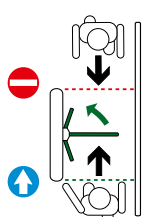

#### Two-directional operation

The Portec turnstile allows for passage from two directions. If people from both directions would like to pass through simultaneously, the first person to activate the sensors for opening takes precedence.

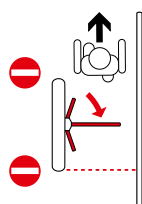

#### Individual opening

After each passage cycle, the turnstile arm again blocks access – only then can the next release for each passage direction take place.

#### Arm movement

3-arm technology (3x120° rotation)

#### Opposite direction block

After each person, the turnstile arm again blocks passage, and therefore does not permit access from the opposite direction unless permanently open is engaged in the opposite direction.

#### Arm manipulation (panic alarm)

An alarm sounds if an attempt is made to press the turnstile arm without release (in systems with a panic function).

#### Peripheral release devices

Various card readers, biometric scanners, control panel, random generator, difference counting, permanently open function, others on request.



#### Escape route

In the event of an emergency, the swivel arms can be opened in both directions. They can be rotated freely when power supply is disconnected, and reset automatically when the power is switched back on.

#### Acoustic alarm

Alarm sirens signal panic opening.

#### Operating status indicator (optional)

Integrated LED clusters signal the operating status of the turnstile in entry and exit.

| LED status indicator |             |
|----------------------|-------------|
|                      | LED cluster |
| Release              | Green       |
| Standby              | Red         |

# 03.03 Portec

## Technical specifications

### Material/surface

Tube housing: Stainless steel or chrome-plated steel, plastic powder-coated cast aluminium parts.  
Arms: Stainless steel.

### Passage rate

For one-time release up to 25 people/minute (depending on the concept).

### Interfaces, connecting devices

Reader device in entry and exit direction.

### Turnstile arms

Made from aluminium and with three fixed or folding, panic-safe arms made from stainless steel.



| Turnstile mechanism with three arms tube Ø 35 (mm) |            |             |
|--|------------|-------------|
| Passage width in mm                                | Fixed arms | Hinged arms |
|  | 580        | 580         |
| Arm length (mm)                                    | 530        | 530         |

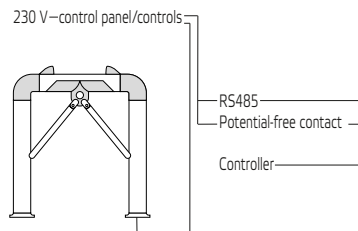

| Turnstiles   |                                   |
|--|-----------------------------------|
|  | Portec                            |
| Electricity supply                                   | 230 V ~ 50 Hz                     |
| Consumption  | 20 Wh                             |
| Rated intake   | 30 VA                             |
| Rated current  | 0.13 A                            |
| Communication interface                              | Contacts, RS 485                  |
| Protection class                                     | II                                |
| Degree of protection for the turnstile/control panel | IP34 / IP20                       |
| Ambient temperature for the turnstile/control panel  | -25° C to +40° C / 0° C to +30° C |
| Weight   | 42 kg                             |

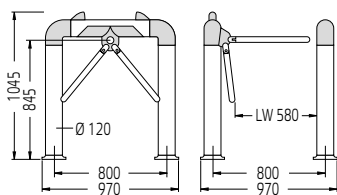

**PORTEC EP**  
with counterpart

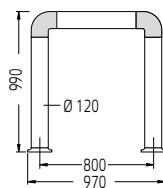

**COUNTERPART**

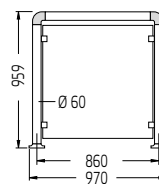

**GUIDANCE ELEMENT**

**Installation surfaces**  
Concrete foundation C25/30 or ground with a minimum compressive strength of 25N/mm<sup>2</sup>, flatness tolerance of +/- 5mm

LW = inner clearance/passage width

## 03.04 Transtec

*Aesthetically sophisticated turnstile*

- > Drive integrated into central column to save space
- > 120° rotation with barriers made of toughened safety glass
- > For one-way and two-way operation



**TRANSTEC**  
with guidance elements



# 03.04 Transtec

■ **Motorised synchronous turnstile.** The go-to product for sophisticated architectural interior environments, such as banks, insurance companies, spa areas, casinos or hotels.

## Design

**Central upright** made from stainless steel with an integrated drive and blocking elements made from single-pane safety glass. One-way or two-way operation. Rotation starts automatically once touched. External control.

**Channelling elements** made from curved acrylic glass with stainless steel handrail.

**Folding door** made from stainless steel with an integrated drive and blocking element made from single-pane safety glass or as a tube arm. One-way or two-way operation; entry direction can be changed.

## Accessories

Folding doors for indoor or outdoor areas, as wheelchair-accessible access or personnel passage, upright for card reader device, external power unit and controls.



**Clearance signal** in direction of entry and exit using potential-free contact (e.g. card reader, operating panel, button, etc.).



For wheelchair-accessible passage and for emergencies, a pedestrian door such as the Galaxyport should be provided with a **panic function**. The panic function releases passage in both directions in the event of an emergency.

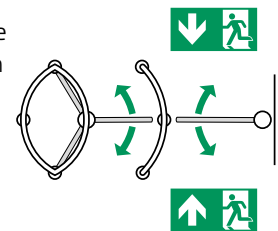

| Transtec  |                             |                                |                                 | Accessories                       |
|---|-----------------------------|--------------------------------|---------------------------------|-----------------------------------|
|   | Turnstile<br>for indoor use | Folding door<br>for indoor use | Folding door<br>for outdoor use | Upright<br>for card reader device |
| Consists of:<br>- Central upright<br>- Guidance elements<br>- Interface: potential-free contacts<br>- Manufacturing standard: DIN-ISO 9001<br>The central uprights can be freely rotated and the folding doors can be freely swivelled when power supply is disconnected. |                             |                                |                                 |                                   |
| <b>Surface</b>  | <b>Prod. no.</b>            | <b>Prod. no.</b>               | <b>Prod. no.</b>                | <b>Prod. no.</b>                  |
| Stainless steel   | 23.37296.95                 | 23.92101.95                    | 23.74036.95-0000                | 23.20833.09                       |

## 03.04 Transtec

### Technical information

#### Transtec functions

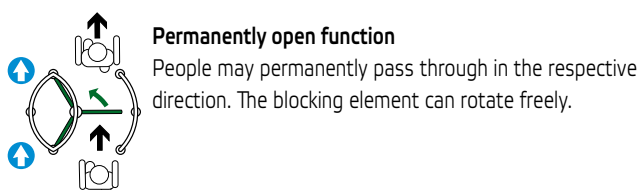
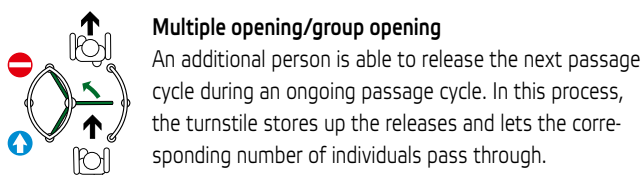
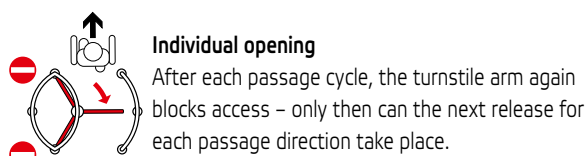
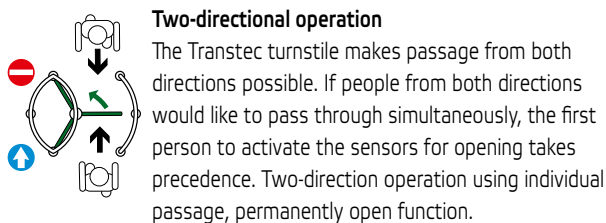

#### Opposite direction block

After each person, the turnstile arm again blocks passage, and therefore does not permit access from the opposite direction.

#### Arm movement

- 3x120° rotation
- Rotation stop in the event of arm contact

#### Peripheral release devices

Various card readers, biometric scanners, emergency button, control panel, control panel with random generator or preselection function, external light barrier, radio remote control, permanently open function, others on request.

#### Emergency exit

Can be rotated freely when power supply is disconnected; setup is configured automatically when the power is switched back on.

#### Fire alarm contact

Break contact connection to central fire alarm system. Automatic opening to allow wheelchair-accessible passage – permanently open.

#### Feedback contact

Passage confirmation for external systems.

#### Transtec folding door functions

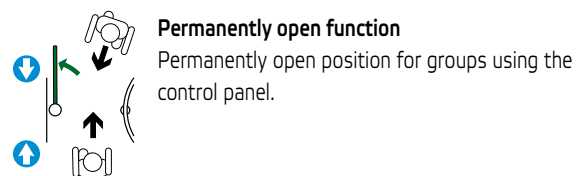
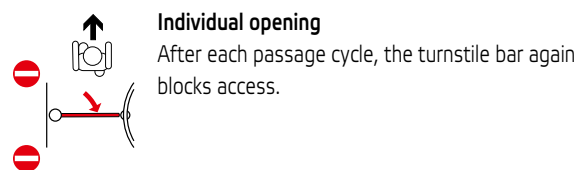
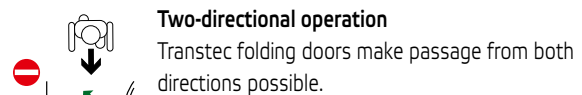

#### Arm movement

- 2x 90°
- Rotation stop in the event of arm contact

#### Peripheral release devices

Various card readers, biometric scanners, emergency button, control panel, radio remote control, permanently open function, others on request.

#### Emergency exit

Connection to fire alarm system (open or close contact). Can be rotated freely when not supplied with power; set up is configured automatically when the power is switched back on.

#### Fire alarm contact

Open or close contact.

#### Feedback contact

Passage confirmation for external systems.



## 03.04 Transtec

### Technical Transtec specifications

#### Material/surface

Turnstile arms: Stainless steel with blocking elements made from 10 mm toughened safety glass.

Guidance elements: made from 15 mm acrylic glass with stainless steel handrail.

#### Sensor system

Contact sensor.

#### Passage rate

For one-time release up to 15 people/minute (depending on the concept).

#### Interfaces, connecting devices

Potential-free closing contact; four configurable connection options in the entry and exit direction, four configurable feedback contacts.

#### Controls and power unit

External.

### Technical Transtec folding door specifications

#### Material/surface

Folding door: Stainless steel with blocking element made from 10 mm toughened safety glass or tube arm with a tube  $\varnothing$  of 30 mm.

#### Sensor system

Contact sensor.

#### Passage rate

For one-time release up to 10 people/minute (depending on the concept). Permanently open function for groups.

#### Interfaces, connecting devices

Potential-free closing contact; four configurable connection options in the entry and exit direction, four configurable feedback contacts.

#### Controls and power unit

External.

| Turnstile            | Transtec          | Transtec folding door        |
|----------------------|-------------------|------------------------------|
| Electricity supply   | 230 V ~, 50-60 Hz | 230 V ~, 50-60 Hz            |
| Consumption          | 20 Wh             | 20 Wh                        |
| Power consumption    | 50 VA max.        | 50 VA max.                   |
| Rated current        | 0.88 A            | 0.88 A                       |
| Protection class     | I                 | I                            |
| Degree of protection | IP 43             | IP 43 - can be used outdoors |
| Ambient temperature  | -5°C to +50°C     | -25°C to +40°C               |
| Weight               | 110 kg            | 50 kg                        |

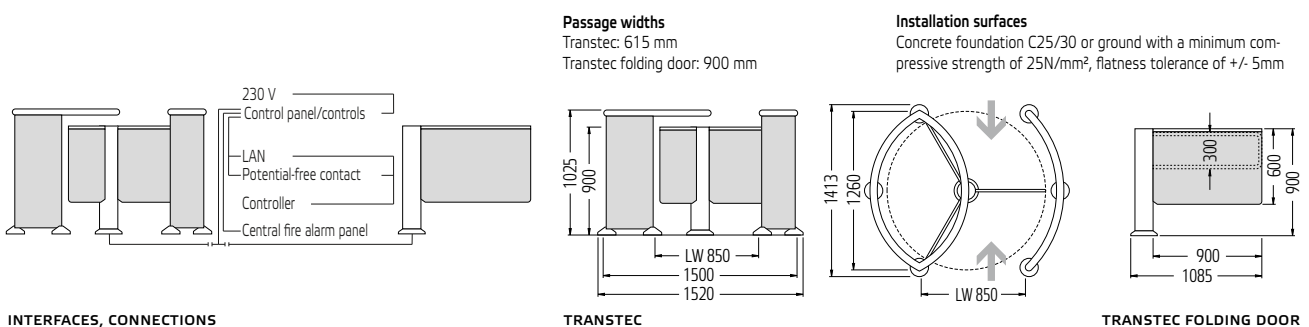

LW = inner clearance/passage width

# 03.05 Low Atlas

*Motor-driven turnstile*

- > *Reliable and proven technology for indoor and outdoor use*
- > *Barrier elements in 90° or 180° arrangement*
- > *Integrated control for two-way operation*



**ATLAS 141 H**  
Height 1100 mm, guidance element (accessories from stainless steel partition system components)



**ATLAS 141 H**  
Height 1100 mm



**ATLAS 241 H**  
Height 1100 mm



## 03.05 Low Atlas

### ■ Atlas turnstiles in half-height design.

Particular examples of successful use include for paid access to swimming pools, museums and leisure parks.

### Design

**Turnstile with** barrier arms, 90° or 180°. Maintenance-free, electric motor drive. One-way and two-way operation possible. Can be rotated freely when power supply is disconnected. Integrated control unit. Side panels made of transparent acrylic glass. Easy assembly.

### Arm movement

- 4x 90° rotation
- 2x 180° rotation
- Rotation will stop in the event of arm contact

### Optional equipment

Base support set, LED release signal.

### Accessories

Holders for peripheral devices, standard control panels or with random generator, access doors, e.g. for pushchairs or wheelchair access, guidance elements.



**Release signal** in direction of entry and exit using potential-free contact (e.g. card reader, operating panel, button, etc.).



For wheelchair-accessible passage and for emergencies, a pedestrian door such as the Galaxyport should be provided with a **panic function**. The panic function releases passage in both directions in the event of an emergency.

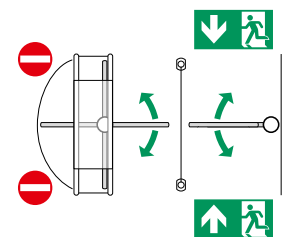

| Atlas low gate turnstiles   | Atlas 141 H      | Atlas 241 H      | Accessories            |
|---|------------------|------------------|------------------------|
| The turnstiles can be turned freely when the power is disconnected. |                  |                  | Galaxyport access door |
| <b>Surface</b>  | <b>Prod. no.</b> | <b>Prod. no.</b> | <b>Prod. no.</b>       |
| Stainless steel, height 1100 mm, 3 arms                             | 23.23083.09      | 23.32010.09      | see Galaxyport         |
| Stainless steel, height 1300 mm, 4 arms                             | 23.59808.09      | 23.59921.09      | see Galaxyport         |

Saltwater-resistant version (V4A) available on request.

# 03.06 Atlas

*Motor-driven gate turnstile*

- > *Reliable and proven technology for indoor and outdoor use*
- > *Barrier elements in 120° arrangement*
- > *Integrated control for two-way operation*



**ATLAS 132 S**  
including control cabinet (accessories)



Atlas 132B with clearance for bicycles



Atlas 232S



Atlas 132S, combination with door



Atlas 132S



Atlas 132S, combination with door

# 03.06 Atlas

■ **Atlas gate turnstiles.** Particular examples of successful use include in works perimeter access systems, sports and recreation facilities, and open-air swimming pools.

## Design

Turnstile with barriers or arms in 120° arrangement. Maintenance-free, electric motor drive. One-way and two-way operation possible. Can be rotated freely when power supply is disconnected. Integrated control unit. Easy assembly.

**Housing, control cabinet** made from plastic powder-coated sheet steel or stainless steel.

**Arm movement** 3x 120° rotation, rotation will stop in the event of arm contact.

## Optional equipment

Canopies, rain drains, lighting with twilight switch, base support set, LED release signal, exit prevention in the event of power failure.



## Accessories

Holders for peripheral devices, standard control panels or with random generator, pedestrian doors, e.g. for pushchairs or wheelchair access.

**Clearance signal** in direction of entry and exit using potential-free contact (e.g. chip or card reader, operating panel, button, etc.).



**Passages** in one or both directions depending on the design and release.  
**Panic function:** The door can **optionally** be fitted with various components, such as an escape door

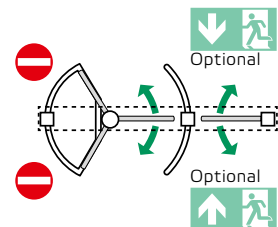

| Atlas gate turnstiles  |                  |                  | Accessories                   |                       |
|--|------------------|------------------|-------------------------------|-----------------------|
|  | Atlas 131        | Atlas 132        | Atlas 132 S (control cabinet) | Atlas pedestrian door |
| The turnstile can be rotated freely when power supply is disconnected. |                  |                  |                               |                       |
| <b>Surface</b>   | <b>Prod. no.</b> | <b>Prod. no.</b> | <b>Prod. no.</b>              | <b>Prod. no.</b>      |
| Stainless steel  | 23.45432.95      | 23.44867.95      | 23.37183.95                   | 23.54594.95           |
| Stainless steel + hot galvanised steel                                 | 23.45432.55      | 23.44867.55      | 23.37183.55                   | 23.54594.55           |

Completely coloured plastic powder-coated systems and other designs (e.g. double gate turnstiles, gate turnstiles with clearance for bicycles, etc.) on request.

## 03.05-03.06 Low Atlas, Atlas

### Technical information

#### Atlas functions

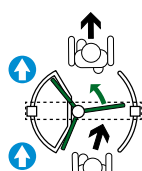
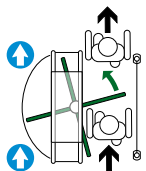
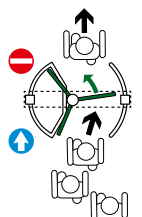
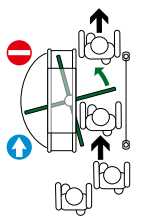
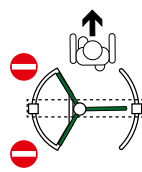
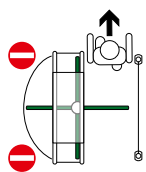
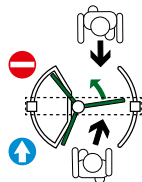
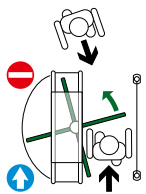

LOW ATLAS

ATLAS

#### Two-directional operation

The Atlas turnstile makes passage from both directions possible. If people from both directions would like to pass through simultaneously, the first person to activate the sensors for opening takes precedence.

#### Individual opening

After each passage cycle, the turnstile arm again blocks access – only then can the next release for each passage direction take place.

#### Multiple opening

An additional person is able to release the next passage cycle during an ongoing passage cycle. In this process, the turnstile stores up the releases and lets the corresponding number of individuals pass through.

#### Permanently open function

People may permanently pass through in the respective direction. The blocking element can rotate freely.

#### Opposite direction block

After each person, the turnstile arm again blocks passage, and therefore does not permit access from the opposite direction.

#### Additional Atlas functions

##### Peripheral release devices

Various card readers, biometric scanners, emergency button, control panel, control panel with random generator or preselection function, radio remote control, permanently open function, others on request.



##### Emergency exit

Can be rotated freely when power supply is disconnected; set up is configured automatically when the power is switched back on.



##### Fire alarm contact

Break contact connection to central fire alarm system. Automatic opening to allow wheelchair-accessible passage – permanently open.

##### Feedback contact

Passage confirmation for external systems.

#### Display

##### Operating status indicators (optional)

Integrated LED clusters/traffic lights signal the operating status in entry and exit direction.

| Status indicator | Atlas low with LED clusters | Atlas with traffic lights |
|------------------|-----------------------------|---------------------------|
| Release          | Green                       | Green                     |
| No passage       | Red                         | -                         |

# 03.05-03.06 Low Atlas, Atlas

## Technical features of the Low Atlas and Atlas

### Material/surface

Low Atlas: Polished stainless steel, acrylic glass.  
 Atlas: Polished stainless steel, powder-coated aluminium.

### Sensor system

Contact sensor.

### Passage rate

Low Atlas: For one-time release up to 15 people/minute (depending on the concept).  
 Atlas: For one-time release up to 15 people/minute (depending on the concept).

### Installation surfaces

Low Atlas and Atlas: Concrete foundation C25/30 or ground with a minimum compressive strength of 25N/mm<sup>2</sup>, installation surface flatness tolerance of +/- 5mm, finished floor level  
 Atlas: plaster subsurface with integrated base supports.

### Interfaces, connecting devices

Four configurable connection options in the entry and exit direction, four configurable feedback contacts.

### Low Atlas turnstiles

with straight arms in a 4x 90° or 2x 180° arrangement.

### Atlas turnstiles

with straight or curved arms in a 3x 120° arrangement.

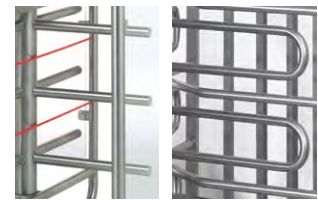

Straight arms      Curved arms

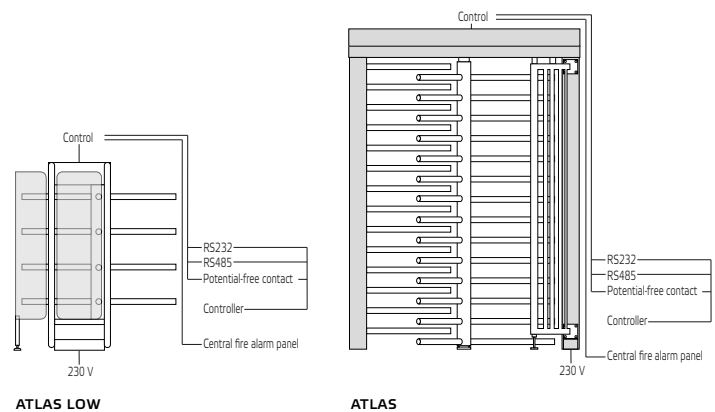

| Gate turnstiles        | Atlas low                        | Atlas                            |
|------------------------|----------------------------------|----------------------------------|
| Electricity supply     | 230 V~, 50-60 Hz                 | 230 V~, 50-60 Hz                 |
| Consumption            | 35 Wh                            | 35 Wh                            |
| Power consumption      | 200 VA max.                      | 100 VA max.                      |
| Rated current          | 0.88 A                           | 0.88 A                           |
| Recommended mains fuse | 10 AT                            | 10 AT                            |
| Protection class       | I                                | I                                |
| Degree of protection   | IP43 in accordance with EN 60529 | IP43 in accordance with EN 60529 |
| Ambient temperature    | +5°C to +50°C                    | -25°C to +40°C                   |
| Weight                 | depending on the design          | depending on the design          |

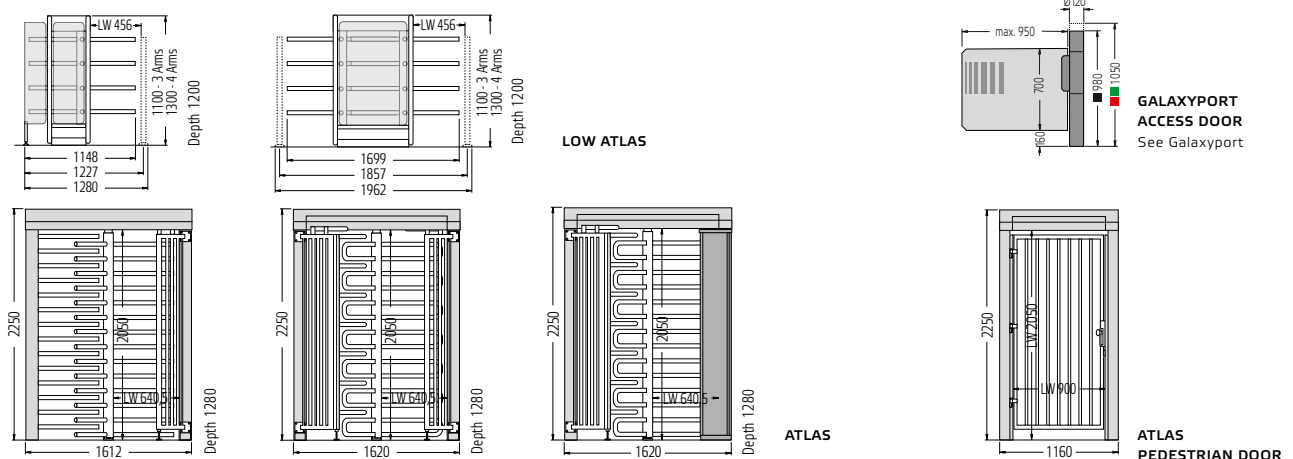

LW = inner clearance/passage width

# 03.07 Example installations

*Turnstiles – for reliable separation of individuals, and monitoring*

- > *Sport, fitness and leisure facilities*
- > *Public institutions, airports, trade fairs and exhibitions*
- > *Personnel access points for companies and officers*

Fig. 1

## **TWO SIRIO UNITS**

Stainless steel partition with toughened safety glass

Fig. 2

## **FOUR SIRIO UNITS**

Card reader, stainless steel partition with toughened safety glass, Technoport with toughened safety glass swivel arm

Fig. 3

## **EASYGO WITH TICKET MACHINE**

Classic partition

Fig. 4

## **TWO SIRIO UNITS**

Double eGate with toughened safety glass swivel arms, U profiles for wiring in the floor, stainless steel partition with toughened safety glass

Fig. 5

## **TWO TRANSTEC UNITS**

Two Transtec pedestrian doors, two uprights with card readers, partition with toughened safety glass





## 03.07 Example installations

■ **Monitoring access authorisation and the separation of individuals are important requirements when it comes to the protection of areas, plants and buildings.**

Fig. 1

**TRANSTEC**

Two Transtec pedestrian doors

Fig. 2

**LOW ATLAS**

Card reader, stainless steel partition with different safety glass, Technoport access door with individual swivel arm

Fig. 3

**ATLAS**

With control cabinet, Atlas pedestrian door

Fig. 4

**ATLAS**

With control cabinet, card reader, door station with camera, canopie

Fig. 5

**ATLAS**

With control cabinet, card reader, door station, canopie

Fig. 6

**DOUBLE ATLAS**

With control cabinet, LED clusters for release indication

Fig. 7

**ATLAS**

With control cabinet, card reader

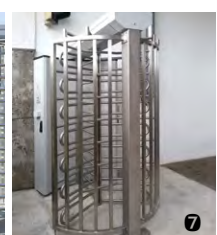

---

# 04 Product overview

---

## 04.01 Galaxy box



01 "SWALLOWING" CARD READER

---

## 04.02 PC control unit



04 FUNCTION APP

---

## 04.03 FMCU



05 FACILITY MANAGEMENT CONTROL UNIT

---

## 04.04 ESD



06 ELECTROSTATIC DISCHARGE PROTECTION

---

## 04 Access Solutions accessories



# 04.01 Galaxy box

Reliable "swallowing" card reader for RFID cards

- > Accurate reading and reliable card intake
- > LED indication and info screen to guide the user
- > Large collection volume



**GALAXY BOX**  
"Swallowing" card reader,  
standing version with info screen

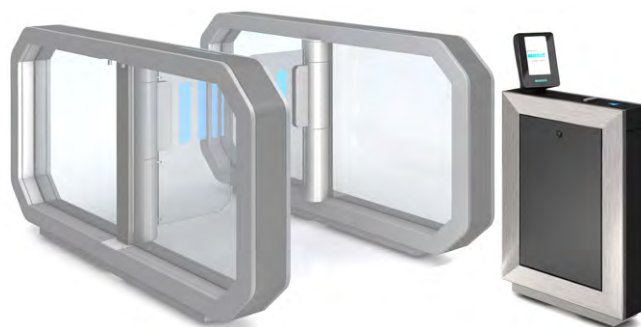

**GALAXY BOX**  
"Swallowing" card reader for controlling a Galaxy Gate

## Functions

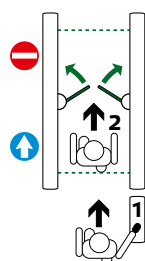

Visitors insert RFID plastic or paper cards into the integrated card intake slot. In the event of authorisation, the card is accepted and directed to the collection container. An opening signal is sent to the entry or exit system.

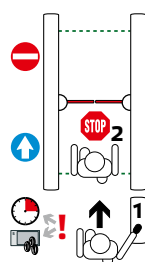

Cards without sufficient authorisation are not accepted, e.g. in the event of a specific period being exceeded in a swimming pool. Following successful additional payment\*, the card is accepted and the opening signal is sent to the entry or exit system.

## Design

Polished and brushed stainless steel housing. Integrated card acceptance device with RFID reader. Card capacity of approximately 1000 units with LED arrow indication of maximum fill level. An RFID reader for special opening and an information screen can be integrated as optional extras.

| Galaxy box   | "Swallowing" card reader      |
|--|-------------------------------|
| Consists of: <ul style="list-style-type: none"> <li>- Housing</li> <li>- Card acceptance device with RFID reader</li> <li>- Card container with lock</li> <li>- Manufacturing standard: DIN-ISO 12100-1, DIN-ISO 12100-2, DIN-EN 60335-1,</li> </ul> |                               |
| Surface<br>Polished and brushed stainless steel  | Prod. no.<br>23.35528.09-0000 |

| Galaxy box             | "Swallowing" card reader |
|------------------------|--------------------------|
| Electricity supply     | 230 V ~ 50-60 Hz         |
| Power consumption      | 75 VA max.               |
| Rated current          | max. 1.2 A               |
| Recommended mains fuse | 10 AT                    |
| Protection class       | I                        |
| Degree of protection   | IP 20                    |
| Ambient temperature    | - 5° C to + 50° C        |
| Weight                 | 50 kg                    |

\* For additional payment machines, see section titled Ticket Machines

# 04.02 PC control unit

Function app for access control systems

- > Controlling the basic status
- > Manual opening by operating personnel
- > Entry/exit difference counting

■ The **PC control unit** is used to control locks, entry and exit systems and turnstiles via a PC or mobile device.

## Minimum PC requirements

Windows operating system: version 7 or later  
 PC system: x86 or x64 with minimum 4 GB RAM  
 and 2 GB HDD or SSD  
 Interface: LAN RJ45  
 System software: MS .NET version 4.0 or later

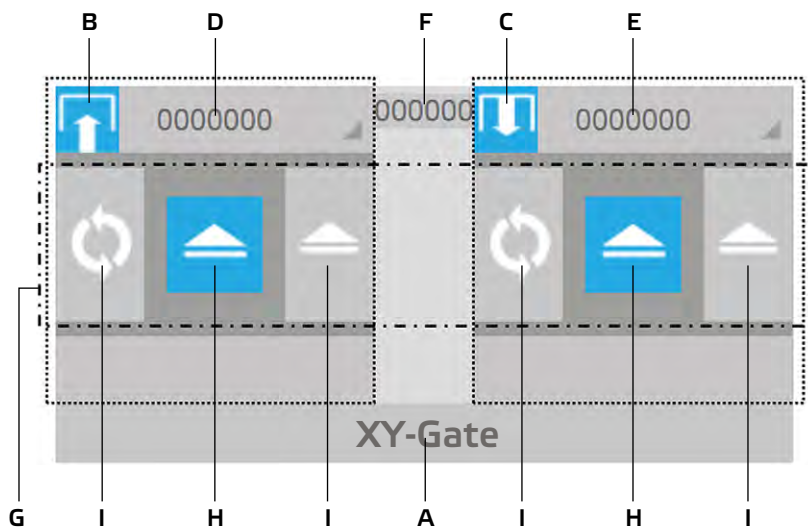



## Menu

- A** Name of access control system
- B** Entry direction
- C** Exit direction
- D** Entry counter (optional, depending on the system configuration and equipment)
- E** Exit counter (optional, depending on the system configuration and equipment)
- F** Difference between the entry counter (D) and the exit counter (E)
- G** Touch-sensitive area with symbols for controlling the system (blue: status active)

## Function

**H = basic statuses of the access control system**

 **Individual release**  
 Through external input on the access control system (e.g. by a card reader)

 **Permanently open**  
 Through external input on the access control system (e.g. by a card reader)

 **Blocked**

**I = manual opening by operating personnel**

 **Permanently open**  
 System opens permanently (symbol turns blue). Closure following repeat operation

 **Individual release**  
 Passage opens (symbol turns blue). Automatic closure after passage or after a certain time period

# 04.03 FMCU

Facility Management Control Unit\_MADE\_BY\_WANZL

- > *Bundling of all control elements with consistent control commands*
- > *Communication using encrypted packages*
- > *Behavioural patterns that can be defined by the user*

■ The **integrated hardware and software** controls and monitors the diverse functions of Galaxy Gate, Galaxy Port and the eGate Checkout, as well as all turnstiles and portal turnstiles. It also makes it possible to connect different hardware products to the access systems, and is responsible for controlling them.

Wanzl FMCU: Printed circuit boards (hardware) as a Facility Management Control Unit, including web access: A standardised interface so that access components are integrated into existing infrastructures at low cost.

WEAC control for Wanzl access systems: High-tech equipment for demanding safety requirements. State-of-the-art control and monitoring technology; visual status indicators; integrated alarm system; can be programmed with a web server; LAN interface; individual voice announcement in MP3 format. Modular technology means this product can be customised to your needs.

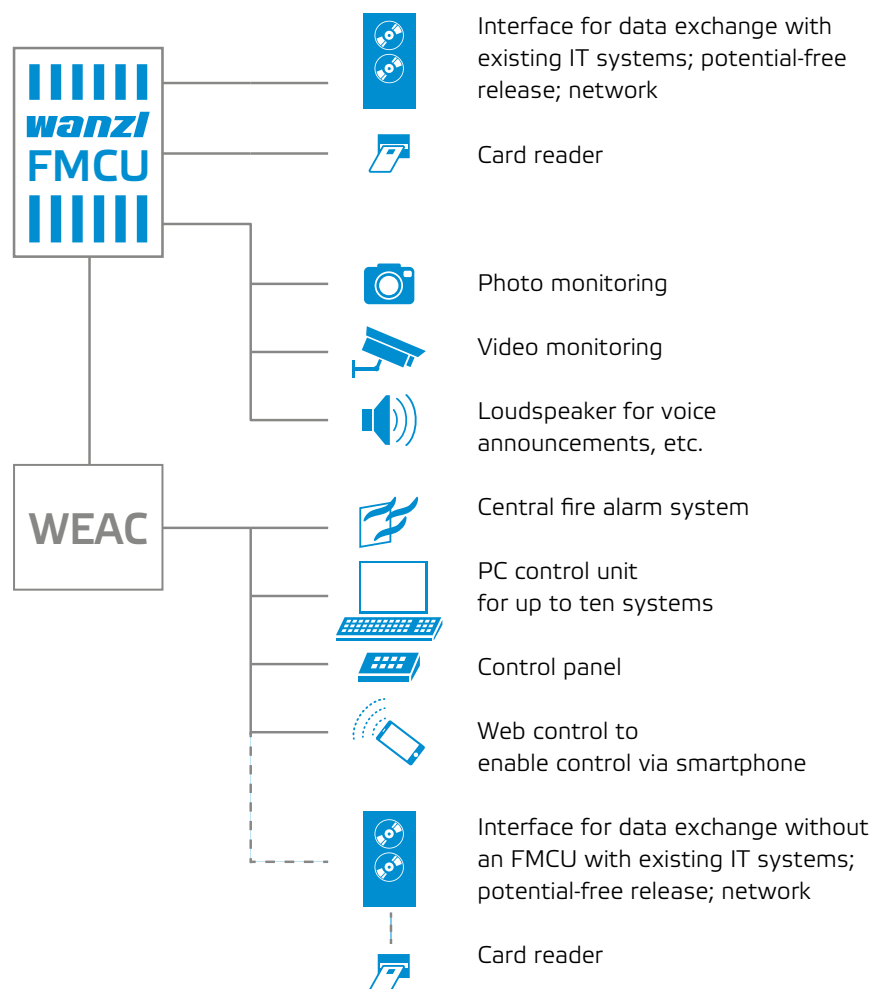

# 04.04 ESD\*

Controlled access for restricted production areas

- > Leak resistance measurement with portable measuring instrument and shoe test electrode
- > Release signal following successful check on access control system

**PORTABLE MEASURING INSTRUMENT**

Checking of electrostatic discharge on hands



**SHOE TEST ELECTRODE**

Testing of electrostatic discharge on shoes

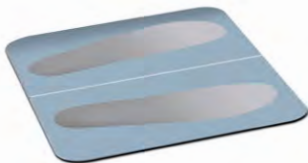

**eGATE COLOUR**

Toughened safety glass swivel arm with safety notice and LED status illumination

■ With **leak resistance measurement**, personal protective ESD measures are reliably checked before entry into the EPA\* and, in order to protect sensitive electronic components, the risk of electrostatic damage is minimised.

**Function**

Checking of people's earthing before each entry into the EPA, and transmission of the release signal to the access control system used. The safety functions on the respective entry system, e.g. the panic function, panic alarm in the event of unauthorised operation, emergency exit etc., continue to function.

**SWIVEL ARM**

Red LED status illumination safety notice: Passage denied



**SWIVEL ARM**

Green LED status illumination safety notice: Passage is permitted

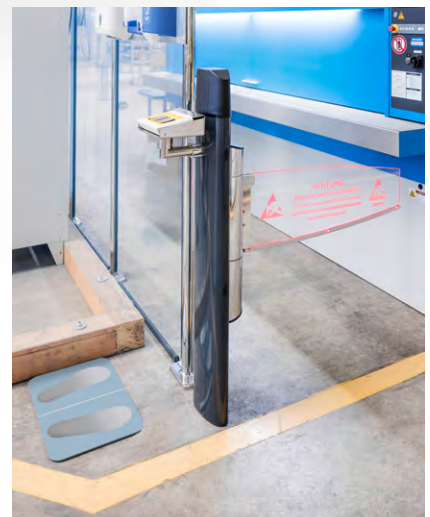

\* ESD Electrostatic Discharge, EPA Electrostatic Protected Area

---

# 05 Product overview

---

## 05.01 Stainless steel partitions



## 05.02 Classic guidance elements





# 05 Guidance elements and partitions



# 05.01 Stainless steel partitions

*Elegant and secure*

- > *Blends in with architecture in sophisticated settings*
- > *Made of stainless steel and single-pane safety glass*
- > *Curved and straight designs*



## STAINLESS STEEL PARTITION

Toughened safety glass pane

Front: straight design

Back: curved design

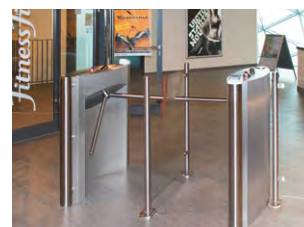

## EXAMPLE

### INSTALLATIONS

with Galaxy Gate, Sirio  
turnstiles and eGate  
entry systems

# 05.01 Stainless steel partitions

■ Attractive and transparent **elements for passage limitation** on entry and exit systems and turnstiles. These versatile and effective stainless steel partitions can also be used as barriers or railings.

## Design

Polished stainless steel tube uprights with stainless steel base plate and base plate cover. Polished stainless steel fixing clips. Curved toughened safety glass panes, ground and polished edges (KPO).

## Restricting and dividing

Stainless steel clamps enable compact wall connections.



## Base plates

Square, with rounding on the narrow side or square with rounded corners.



## Information and design

The glass areas offer plenty of room for labelling with foils, printing or sand-blasting on request. Let your imagination run wild!



## Dimensions (mm)

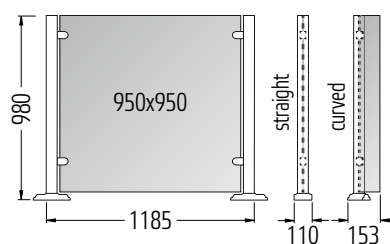

## Assembly

Assembly of uprights on finished floors. For assembly of uprights on a deep concrete layer, see Classic guidance elements.

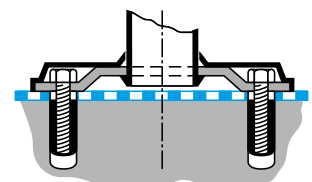

| Stainless steel partition              |                  |                  |                  |                             | Accessories   |
|--|------------------|------------------|------------------|-----------------------------|---|
| Uprights with                          | 2 clamps         | 4 clamps 90°     | 4 clamps 180°    | 6 clamps in a T arrangement | Wall clamps   |
|  |                  |                  |                  |                             |   |
| Surface                                | Prod. no.        | Prod. no.        | Prod. no.        | Prod. no.                   | Prod. no.   |
| Clamp arrangement for the base plate   |                  |                  |                  |                             | 1 unit<br>23.85100.09-0000  |
| Rectangular stainless steel base plate | 23.45472.09-0000 | 23.45585.09-0000 | 23.45698.09-0000 | 23.45811.09-0000            | <b>Glass elements</b>   |
| Clamp arrangement for the base plate   |                  |                  |                  |                             | Straight, transparent toughened safety glass element, 950 x 950 mm: |
| Rectangular stainless steel base plate | 23.45924.09-0000 | 23.46037.09-0000 | 23.46150.09-0000 | 23.46263.09-0000            | 23.23766.00-0002  |
| Clamp arrangement for the base plate   |                  |                  |                  |                             | Curved, transparent toughened safety glass element, 950 x 950 mm:   |
| Square stainless steel base plate      | 23.46602.09-0000 | 23.46715.09-0000 | 23.46828.09-0000 | 23.46941.09-0000            | 77.23286.00-0000  |

# 05.02 Classic guidance elements

*Practical functionality – effective spatial organisation*

- > Partition areas and direct the flow of people
- > Quick and easy adjustment
- > Can be combined with any access system

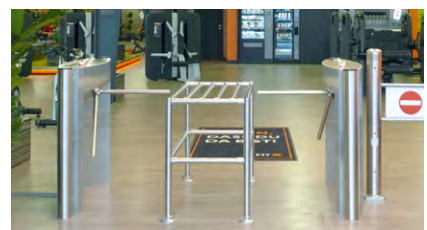
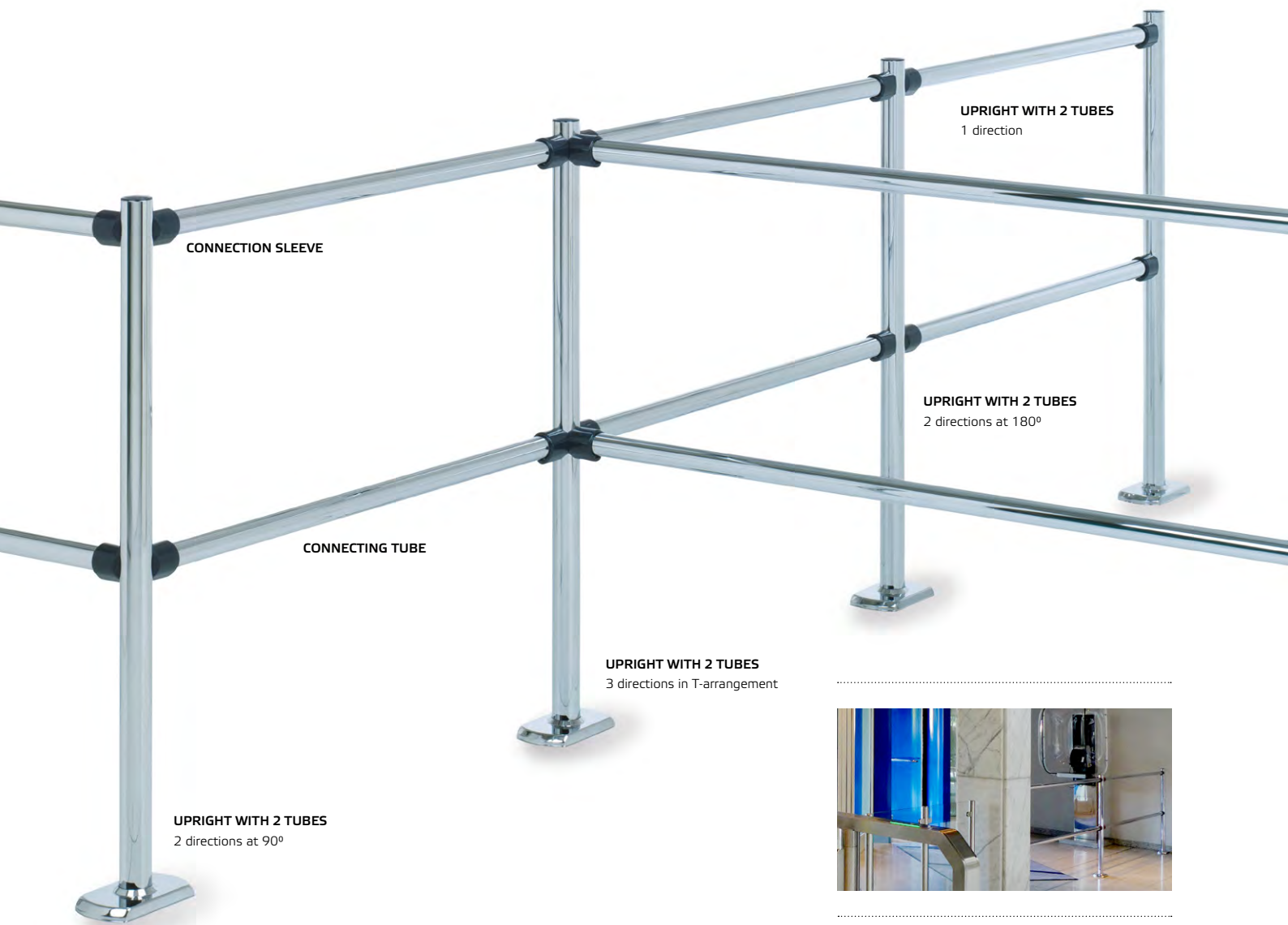

**EXAMPLE USES**  
Guidance elements for room division and with Sirio turnstiles

# 05.02 Classic guidance elements

## Uprights, connecting tubes and partition elements.

A variable system for steering visitors and dividing rooms. Tried and tested as a room divider in many areas, and for attachment to locks, entry and exit systems, and turnstiles.

### Design

Steel tube uprights with diameter of 50 mm and large base plates. Steel base plate cover. Connection sleeves for division with two tubes. Steel connecting tubes with a diameter of 40 mm. Finishing chrome-plated, plastic powder coating or polished stainless steel.

### Optional

Coloured connection sleeves in nine colours and chrome plating. The standard colour is anthracite grey, RAL 7016.



### Assembly

Assembly of uprights on finished floors.

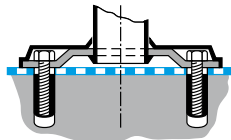

### Optional

For movable barriers – floor socket for removable uprights without a base plate. Internal diameter 50 mm, insertion depth 130 mm.

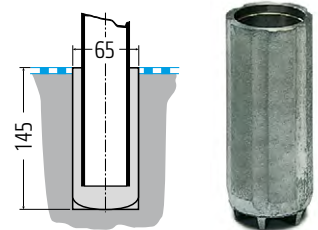

### Assembly with lower concrete layer

Assembly of uprights on fitted floors with spacers and screws of a suitable length.

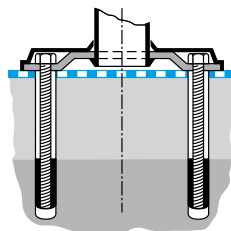

### Dimensions (mm)

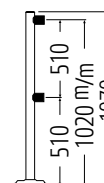

**Upright**  
2 tubes

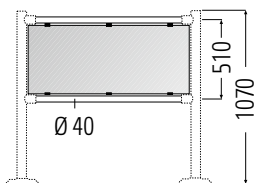

**Partition element**  
Suitable for uprights with 2 tubes

| Classic guidance elements  |                         |                         |                         |                              | Accessories  |
|--|-------------------------|-------------------------|-------------------------|------------------------------|--|
| Uprights   | 2 sleeves               | 4 sleeves 90°           | 4 sleeves 180°          | 6 sleeves in a T arrangement | Connecting tubes   |
| Consists of<br>- Upright with base plate<br>- Connection sleeves |                         |                         |                         |                              | <b>Prod. no.</b><br>500 mm, Ø 40 mm<br>23.04249.10/73/09*<br>1000 mm, Ø 40 mm<br>23.04017.10/73/09*<br>1500 mm, Ø 40 mm<br>23.04018.10/73/09*<br>2000 mm, Ø 40 mm<br>23.04019.10/73/09 |
| <b>Surface</b>   | <b>Prod. no.</b>        | <b>Prod. no.</b>        | <b>Prod. no.</b>        | <b>Prod. no.</b>             | <b>Partition elements</b>  |
| Sleeve arrangement for the base plate                            |                         |                         |                         |                              | Width, 1000 mm<br>23.16298.95**  |
| Plastic connection sleeves                                       | 23.10652.10/73/09-7016* | 23.04747.10/73/09-7016* | 23.10653.10/73/09-7016* | 23.10657.10/73/09-7016*      | Width, 1500 mm<br>23.16299.95**  |
| Metal connection sleeves   | 23.72987.10/73/09*      | 23.04748.10/73/09*      | 23.75513.10/73/09*      | 23.75517.10/73/09*           |  |
| Sleeve arrangement for the base plate                            |                         |                         |                         |                              |  |
| Plastic connection sleeves                                       | 23.10701.10/73/09-7016* | 23.10655.10/73/09-7016* | 23.07273.10/73/09-7016* | 23.10567.10/73/09-7016*      |  |
| Metal connection sleeves   | 23.10702.10/73/09*      | 23.75515.10/73/09*      | 23.07386.10/73/09*      | 23.17187.10/73/09*           |  |

\* Sample orders: 23.10652.10 High-gloss chrome-plated  
23.10652.73 Plastic powder coating, please specify the colour required.  
23.10652.09 Stainless steel

\*\* Please state preferred connection tube design.

---

# 06 Product overview

---

## 06.01 Vending Unit V21



01 PREPAY PAYMENT MACHINE  
with customer card creation

---

## 06.02 Vending Unit V15



02 PREPAY PAYMENT MACHINE,  
TICKET MACHINE  
with and without printing attachment

---

## 06.03 EasyGo with Vending Unit V7



03 PAYMENT ACCESS

---

## 06.04 Example installations



04 PAYMENT AND TICKETING SOLUTIONS

---

# 06 Vending Units



# 06.01 Vending Unit V21

*Interactive ticket machine*

- > *Modular structured peripheral devices*
- > *21" full HD multi touch display*
- > *Cutting-edge design with integrated light control*



Pat. pend.

VENDING UNIT V21



# 06.01 Vending Unit V21

■ Your customers are bound to appreciate the simple, intuitive, **user-friendly operation of the Vending Unit V21**. It is always available for use, meaning staff are free to do other things.

## Design

A premium, slimline design with toughened safety glass front with individual, progressively adjustable colour. 21" full HD multi touch display with interactive menu navigation. Robust plastic powder-coated steel housing.

## Customised

Offers a high degree of flexibility and simple adaptation to relevant requirements through the use of insertable and replaceable **tiles** in the glass front.



## System settings

Configurable charging system. Output of statistics and frequency measurements. Receipt printing. RFID card issue and return, issue of RFID wristbands (HF: high frequency. UHF: ultrahigh frequency).

## Operation

The integrated capacitive multi touch display and interactive user guidance make operation simple, clear and intuitive.

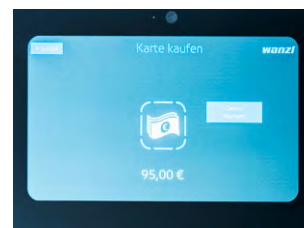

## Highly secure

Patented new door locking technology with security locks that issue an alarm.

## Multiple payment options

Debit/credit card terminal with PIN pad, coin and banknote slots, micropayments via NFC, and more.



| Vending Unit   |                                |
|--|--------------------------------|
|  | V21                            |
| Standard equipment:<br>steel housing, powder-coated Iron Mica 9160.<br>Front made from toughened safety glass with an all-round LED light strip.<br>Integrated 21" multi touch display<br>Patented closure technology<br>Integrated receipt printer<br>LAN interface for data exchange<br>Remote maintenance<br>ETISS software<br>Heater |                                |
| <b>Surface</b><br>Plastic powder-coated steel housing  | <b>Prod. no.</b><br>On request |

## Accessories

Canopy, customised painting of housing, thermal paper rolls (60 x 60 mm, 60 x 90 mm), Leporello for paper tickets; Leporello custom formats (on request), RFID ID cards, cleaning cards for banknote readers, 1D/2D barcode readers.

## Areas of installation











Canteens, swimming pools, hospitals, leisure parks, golf courses, museums, arenas, tourism facilities, cable cars, cinemas, indoor leisure facilities, loyalty cards, connection to ticketing systems.

# 06.01 Vending Unit V21

## Technical information

### Functional features

Based on individual equipment:

-  ↑  ↓ Issuing of tickets
-  ↑  ↓ Prepay machine with top-up function
-  ↑  ↓ Management of customer cards
-  ↑  ↑ Self-checkout
-  ↑  ↓ Info terminal with printing function
-  ↑ Prepay machine

### Payment system design

- Banknote reader with/without change function
- Change machine
- Credit card terminal
- Credit card reader without PIN pad for amounts up to €20
- NFC
- Lockable cash box
- Tokens on request

### Ticket and printing system variant

- RFID ticket issue and return
- RFID paper ticket issue
- RFID reader
- 1D/2D barcode
- Wristband printer
- Receipt or ticket printer

| Vending Unit                                  |                |
|---|----------------|
| V21   |                |
| Currency                                      | On request     |
| Change given                                  | In coins       |
| Automatic sorting                             | ☑              |
| Remote access                                 | ☑              |
| Optional: Credit card acceptance              | ☑              |
| Optional: Banknote acceptance/return          | ☑              |
| Optional: ERP inventory and analysis software | ☑ LAN required |

### Additional functions

- Alarm/silent alarm
- Acoustic notifications
- Interactive camera with motion detection
- Visual LED notification

## 06.01 Vending Unit V21

### Technical specifications

#### Housing made from steel profile and steel sheet

Plastic powder-coated, colour: Iron Mica 9160.

#### Glass front

Toughened safety glass with integrated 21-inch full HD multi touch, extremely hard-wearing.

#### Additional features

All-round LED illumination (RGBW), card dispenser, credit card terminal, acceptance and return of coins and banknotes, drop shaft, machine opening using an RFID card (electronic closure), motion detection by an integrated camera, brightness sensor for optimum machine illumination, plays recorded promotional messages while not in use (standby mode).

#### Software features

ETISS software for centralised management of the machines, encrypted communication, centralised configuration management, remote maintenance, centralised software distribution, cloud support, requesting the status of the individual components (card reader, payment components, printer, etc.), GOBD certification, finance export interface (Datev), user interface in the customer CI, representation of technical process control based on customer requirements, plays recorded promotional messages while not in use (standby mode), notification in the event of thresholds being exceeded, transaction security support, temperature monitoring.

| Vending Unit                                     |   |
|--|---|
|  | V21   |
| Rated power supply                               | 230 V ~, 50 Hz, 4 A or 8 A at 115 V ~, 60 Hz (see identification plate) |
| Rated output                                     | max. 1050 W   |
| Device input fuse                                | B13 automatic fuse, all-pole shutdown, 10 mA ground fault interrupter   |
| Fusing required on mains side                    | 6 A ... 10 A  |
| Protection class                                 | I (protective earthing) in accordance with EN 61140 (VDE 0140-1)        |
| Degree of protection in accordance with EN 60529 | IP X3 (see chapter 2.2)   |
| Use in temperature range                         | -20°C to +45°C (indoor + covered outdoor areas)                         |
| Use in relative humidity                         | 50% to 60%  |
| Operation height                                 | < 2000 m above sea level  |
| LED class  | 1   |
| Empty weight (without coins)                     | approximately 130 kg, depending on the equipment                        |

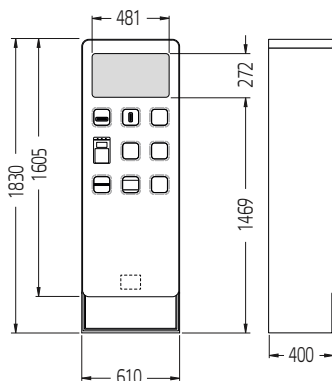

VENDING UNIT V21

# 06.02 Vending Unit V15

*Universal use – efficient without personnel*

- > *Intelligent cash management*
- > *15" PC touchscreen*
- > *Reader for prepaid cards or issuing tickets*



**PREPAY MACHINE**  
without attachment



**TICKET MACHINE**  
with attachment



## 06.02 Vending Unit V15

■ **Prepay payment machine** for canteens, recreational facilities, nightclubs, etc. Top-up and payment of fees/tariffs with customer card.

**Ticket machine** for golf courses, cinemas, museums, indoor climbing walls, etc. Cashless issuing of tickets/tags.

### Prepay payment machine design

15" multi touch screen with interactive menu navigation. Robust, polished stainless steel housing with integrated user-friendly payment functions. Non-contact reader for card identification and authorisation of cash depositing and dispensing. Software for professional management of all machine transactions and settings.

### Ticket machine design

15" multi touch screen with interactive menu navigation. Robust, polished stainless steel housing with cashless payment terminal. Reader for authorisation of membership passes, club cards, etc. Software for professional management of all machine transactions and settings. Graphics-enabled ticket printer. Ticket machine suitable for indoor and outdoor areas with sufficient canopy (accessory).

### Standard equipment Prepaid payment machine

Coin acceptance with automatic sorting. Banknote acceptor with integrated dispensing function. Reader for prepaid cards. Integrated alarm system. Mechanical locking of the cash containers. Two hoppers, each for approx. 900 coins. Cashbox for approx. 1,500 coins. Anti-theft multi-point locking. Till software. Receipt printer. LAN interface for data exchange.

### Standard equipment Ticket machine

Card reader for membership passes, club cards, etc. Integrated alarm system. Anti-theft multi-point locking. Till software. Heating. Graphics-enabled ticket/tag printer. LAN interface for data exchange. Customised light attachment (height 300 mm).

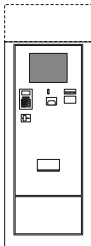
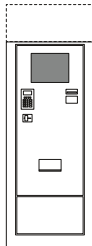









| Vending Units V15                |   |  |
|----------------------------------|---|--|
|                                  | Prepay machine  | Ticket machine   |
|                                  |  |  |
| Surface                          | Prod. no.   | Prod. no.  |
| Polished stainless steel housing | On request  | On request   |
| Accessories                      |   |  |
| Light attachment, custom printed | On request  | On request   |

## 06.02 Vending Unit V15

### Technical Information

#### Functional Features

Based on individual equipment:

-  ↑  ↓ Issuing of tickets
-  ↑  ↓ Prepay machine with top-up function
-  ↑  ↓ Management of customer cards
-  ↑  ↑ Self-checkout
-  ↑  ↓ Info terminal with printing function
-  ↑ Prepay machine

#### Payment system design

- Banknote reader with/without change function
- Change machine
- Credit card terminal
- Credit card reader without pin pad for amounts up to €20
- NFC
- Lockable cash box
- Tokens

#### Ticket and printing system variant

- RFID ticket issue and return
- RFID paper ticket issue
- RFID reader
- 1D/2D barcode
- Wristband printer
- Receipt and ticket printer

| Vending Unit                                  |                         |
|---|-------------------------|
| V15   |                         |
| Currency                                      | All national currencies |
| Change given                                  | In coins                |
| Automatic sorting                             | ☑                       |
| Remote access                                 | ☑                       |
| Optional: Credit card acceptance              | ☑                       |
| Optional: Banknote acceptance/return          | ☑                       |
| Optional: ERP inventory and analysis software | ☑ LAN required          |

#### Additional functions

- Alarm/silent alarm
- Acoustic notifications

## 06.02 Vending Unit V15

### Technical specifications

#### Housing surface

Glass bead blasted, electro-polished, or painted stainless steel

#### Additional features

Card dispenser, credit card terminal, acceptance and return of coins and banknotes, drop shaft, plays recorded promotional messages while not in use (standby mode).

#### Software features

ETISS software for centralised management of the machines, encrypted communication, centralised configuration management, remote maintenance, centralised software distribution, cloud support, requesting the status of the individual components (card reader, payment components, printer, etc.), GOBD certification, finance export interface (Datev), user interface in the customer CI, representation of technical process control based on customer requirements, plays recorded promotional messages while not in use (standby mode), notification in the event of thresholds being exceeded, transaction security support, temperature monitoring.

| Vending Unit                                     |   |
|--|---|
|  | V15   |
| Rated power supply                               | 230 V ~, 50 Hz, 4 A or 115 V ~, 60 Hz, 4 A (see identification plate) |
| Rated output                                     | max. 400 W  |
| Device input fuse                                | B13 automatic fuse, all-pole shutdown, 10 mA ground fault interrupter |
| Fusing required on mains side                    | 6 A ... 10 A  |
| Protection class                                 | I (protective earthing) in accordance with EN 61140 (VDE 0140-1)      |
| Degree of protection in accordance with EN 60529 | IP X3 (see chapter 2.2)   |
| Use in temperature range                         | -20°C to +45°C (indoor + covered outdoor areas)                       |
| Use in relative humidity                         | 50% to 60%  |
| Operation height                                 | < 2000 m above sea level  |
| LED class  | 1   |
| Empty weight (without coins)                     | approximately 120 kg, depending on the equipment                      |
| Optional illumination                            | E27 bulb socket, max. 250 V ~, max. 60 W                              |

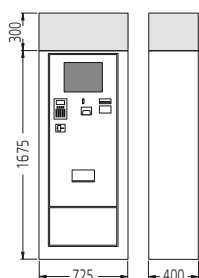

**VENDING UNIT V15**  
Prepay machines

# 06.03 EasyGo with Vending Unit V7

Reliable turnstile with integrated ticket machine

- > Reliable access control for paid entry
- > Stainless steel housing
- > Available with 2 or 3 arms



EASYGO, 2-ARM, WITH VENDING UNIT V7

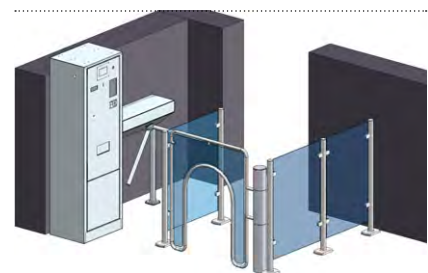
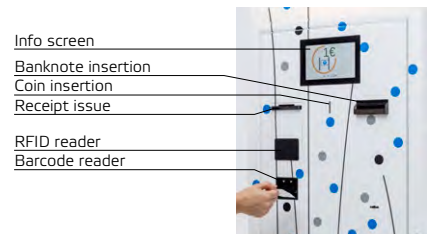



# 06.03 EasyGo with Vending Unit V7

■ **EasyGo Turnstiles with Vending Unit V7** guarantees functional reliability. Design with integrated ticket machines. Reliable access control for paid entry to WC facilities in restaurants, service stations, petrol stations, museums, events and many other areas.

## Design

Fully enclosed stainless steel housing. Integrated ticket machine: Coin system with automatic sorting using a hopper, stores up to approx. 3,000 coins, acceptable coins can be specified, integrated coin acceptor, receipt printer, EasyGo motor-driven turnstile.

## Fast amortisation

**Entry fees** ensure quick amortisation (ROI). Receipt use is optional, e.g. can be redeemed as voucher. See the following page for example calculation.

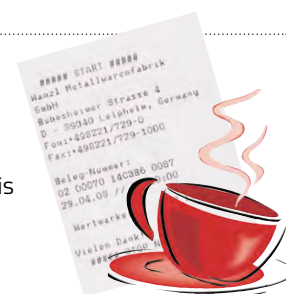

## System adjustment

Configurable charging system. Output of statistics and frequency measurements. Hopper fill level can be specified. Receipt printing.



## Optional equipment

Accepts credit/debit cards and banknotes. Lockable, audit-proof hopper and cashbox. ETISS online till software.

## Software packages

**Standard** with fiscal data logging and local, manual ticket validation.

**Optional** ETISS NG for the provision of system data by email or SMS, system status, online configuration and connection to existing ticketing systems.

## Accessories

Illuminated, customised attachment, access doors for children and wheelchair users, swivel gates for personnel passage or goods transport, etc.



| EasyGo with Vending Unit V7, motor-driven, 2-arm                                      |  |   |  |
|---|--|---|--|
| Ticket machine on the left  | Ticket machine on the right  | Automatic access door   | Personnel entrance/exit  |
|   |  |   |  |
| Prod. no.<br>23.00086.09-0000   | Prod. no.<br>23.00087.09-0000  | Prod. no.<br>23.36319.09-0000   | Prod. no.<br>23.02736.09-V003  |
| Turnstile with integrated ticket machine on the left-hand side, 2-arm pivotal centre. | Turnstile with integrated ticket machine on the right hand side, 2-arm pivotal centre. | Automatic child passage doors with EURO closing cylinders for wheelchair users - wheelchair accessible passage. | With panic function. Self-locking, removable swivel arm, sign with no entry symbols. |

# 06.03 EasyGo with Vending Unit V7

## Technical information

### Functions

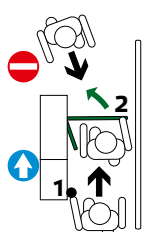

#### Entry

After the entry fee payable has been inserted, the turnstile mechanism allows one person to pass through.

#### Climb-over and/or crawl-under alarm (optional)

An alarm sounds if an attempt is made to crawl under or climb over the turnstile arm.

#### Arm manipulation

If the turnstile arm is pushed on without payment being made, an alarm signal sounds. The arm then automatically returns to the home position.

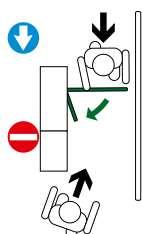

#### Exit

In the exit direction, the turnstile allows one person to pass through when contact is made with the turnstile arm.

#### Operating status indicator

Menu navigation using the machine display.

#### Further functions

See EasyGo turnstile.



### The entry and reimbursement principle: customer service that pays

When they use the system subject to a fee, customers receive a voucher. After using the system, the voucher can be redeemed to the value of some or all of the fee paid. When the voucher is redeemed in the restaurant, kiosk or

shop, you generate additional sales and investment costs and amortise within a short period of time.

| Example calculation 1   |         |             |                         |  |              |  |
|---|---------|-------------|-------------------------|--|--------------|--|
| Amount  | Voucher | Fee         | Average consumption/fee | Example calculation  |              |  |
| €0.70   | €0.50   | €0.20       | €2.00                   | 25% of all vouchers are not redeemed<br>75% voucher redemption |              |  |
| Toilet use  | Number  | in €        | Average consumption     | Vouchers not redeemed  | Total income |  |
| Daily   | 500     | €350.00     | €750.00                 | €88.00   | €838.00      |  |
| Monthly   | 15,000  | €10,500.00  | €22,500.00              | €2,625.00  | €25,125.00   |  |
| Annually  | 180,000 | €126,000.00 | €270,000.00             | €31,500.00   | €301,500.00  |  |
| <b>The gross income (including VAT) per year is €301,500.</b> |         |             |                         |  |              |  |
| Example calculation 2   |         |             |                         |  |              |  |
| Amount  | Voucher | Fee         | Average consumption/fee | Example calculation  |              |  |
| €0.70   | €0.50   | €0.20       | €2.00                   | 10% of all vouchers are not redeemed<br>90% voucher redemption |              |  |
| Toilet use  | Number  | in €        | Average consumption     | Vouchers not redeemed  | Total income |  |
| Daily   | 300     | €210.00     | €540.00                 | €21.00   | €561.00      |  |
| Monthly   | 9,000   | €6,300.00   | €16,200.00              | €630.00  | €16,830.00   |  |
| Annually  | 108,000 | €75,600.00  | €194,400.00             | €7,560.00  | €201,960.00  |  |
| <b>The gross income (including VAT) per year is €201,960.</b> |         |             |                         |  |              |  |

## 06.03 EasyGo with Vending Unit V7

### Technical specifications

#### Turnstile housing

Polished stainless steel.

#### Low-maintenance mechanism

Single or two-rung operation.



#### Ticket machine housing

Glass bead blasted, electro-polished, or painted stainless steel.

#### Display

7" glass colour touchscreen with visual user guidance.

#### Passage rate

12 people per minute (depending on the concept).

#### Interfaces, connecting devices

On request.

#### Ticket machine

Accepts coins, voucher printing from the front of the machine, with withdrawal in the event of non-removal (voiding), LED illumination on the output tray during campaigns, integrated alarm system.

#### Optional equipment

Lightbox, coating in RAL colour or stickers, banknote acceptance with a change function, reader device for magnetic, contact-based or contactless credit cards, NFC payment using a card or smartphone, integrated ticket validator (barcode reader), token acceptance, integrated heating, cover plate for the coin box, three hoppers for a coin change function, cover plate for the hoppers, customised colour display logo and voucher layout, menu in a second language (language selected using flags), RFID chips for personnel.

| EasyGo with Vending Unit V7                      |   |
|--|---|
|  | left/right  |
| Rated power supply                               | 230 V ~, 50 Hz, 4 A or 8 A at 115 V ~, 60 Hz (see identification plate) |
| Rated output                                     | max. 1050 W   |
| Device input fuse                                | B13 automatic fuse, all-pole shutdown, 10 mA ground fault interrupter   |
| Fusing required on mains side                    | 6 A ... 10 A  |
| Protection class                                 | I (protective earthing) in accordance with EN 61140 (VDE 0140-1)        |
| Degree of protection in accordance with EN 60529 | IP X3 (see chapter 2.2)   |
| Use in temperature range                         | -20°C to +45°C (indoor + covered outdoor areas)                         |
| Use in relative humidity                         | 50% to 60%  |
| Operation height                                 | < 2000 m above sea level  |
| LED class  | 1   |
| Empty weight (without coins)                     | approximately 150 kg, depending on the equipment                        |
| Optional illumination                            | E27 bulb socket, max. 250 V ~, max. 60 W                                |

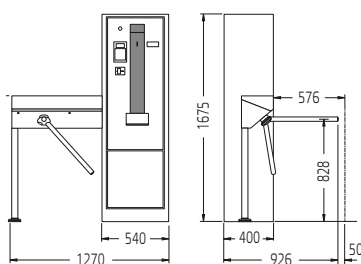

**EASYGO WITH VENDING UNIT V7**  
2-arm

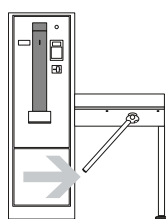

Ticket machine  
on the left

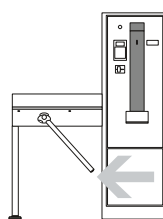

Ticket machine  
on the right

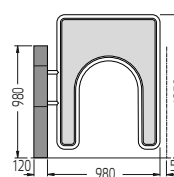

**AUTOMATIC ACCESS DOOR**  
Child passage door

# 06.04 Example installations

*Machine operation is automatically reliable*

- > Sport, fitness and leisure facilities
- > Public institutions, airports, trade fairs and exhibitions
- > Personnel access points for companies and offices

Fig. 1  
**EASYGO WITH VENDING UNIT**  
Classic partition

Fig. 2  
**EASYGO WITH VENDING UNIT**  
Classic partition, stainless steel partition with toughened safety glass

Fig. 3  
**VENDING UNIT V21**

Fig. 4  
**EASYGO WITH VENDING UNIT**  
Automatic access door – child passage, wheelchair accessible

Fig. 5  
**VENDING UNIT V15**  
Illuminated attachment

Fig. 6  
**EASYGO WITH VENDING UNIT**  
Swivel gate with tall swivel arm, Classic partition

Fig. 7  
**VENDING UNIT V15**  
Canopy, output units



## 06.04 Example installations

■ In many areas, machines take on automated tasks, take over administration tasks from personnel, and free up the time employees need to perform their actual work.

Fig. 1

**VENDING UNIT V15**  
Ticket issue

Fig. 2

**VENDING UNIT V15**  
Ticket issue, stainless steel partition with toughened safety glass



---

# 07 Product overview

---

## 07.01-07.03 ETISS software



<sup>01</sup> ETISS ERP CONTROLS FOR LOCKS, ENTRY SYSTEMS AND TURNSTILES



<sup>02</sup> ETISS ERP WITH POS – MANAGING THE POINT OF SALE



<sup>03</sup> ETISS NG – MANAGING TICKET MACHINES

---

## 07.04 ETOSS software



<sup>04</sup> MANAGEMENT MODULE FOR A RANGE OF COMPONENTS

---

# 07 Software

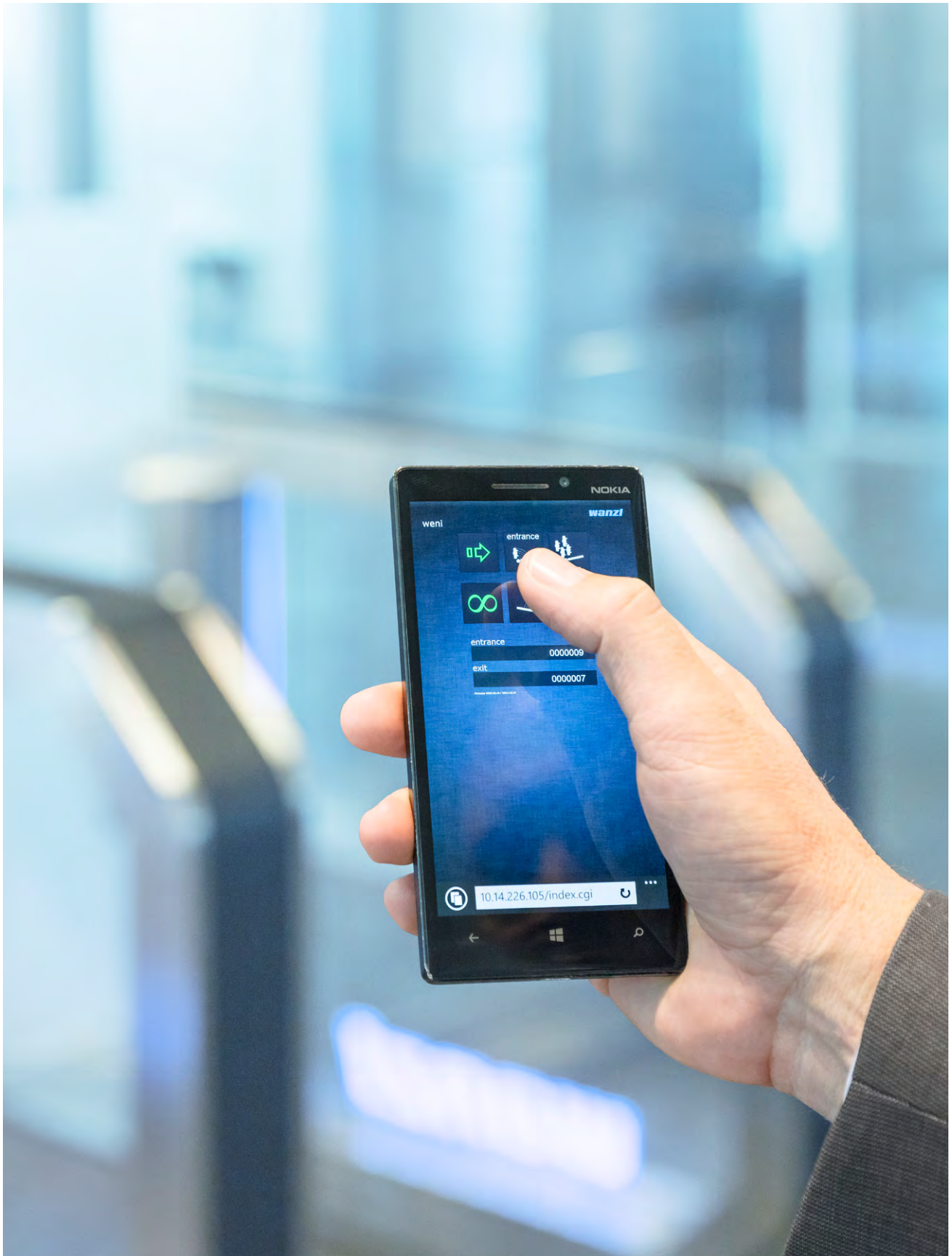

# 07.01 ETISS ERP

Management Software\_Made\_by\_Wanzi

- > Support for all operating systems
- > Standardised interfaces for a variety of hardware components
- > Network capacity with centralised controls for all decentralised machines

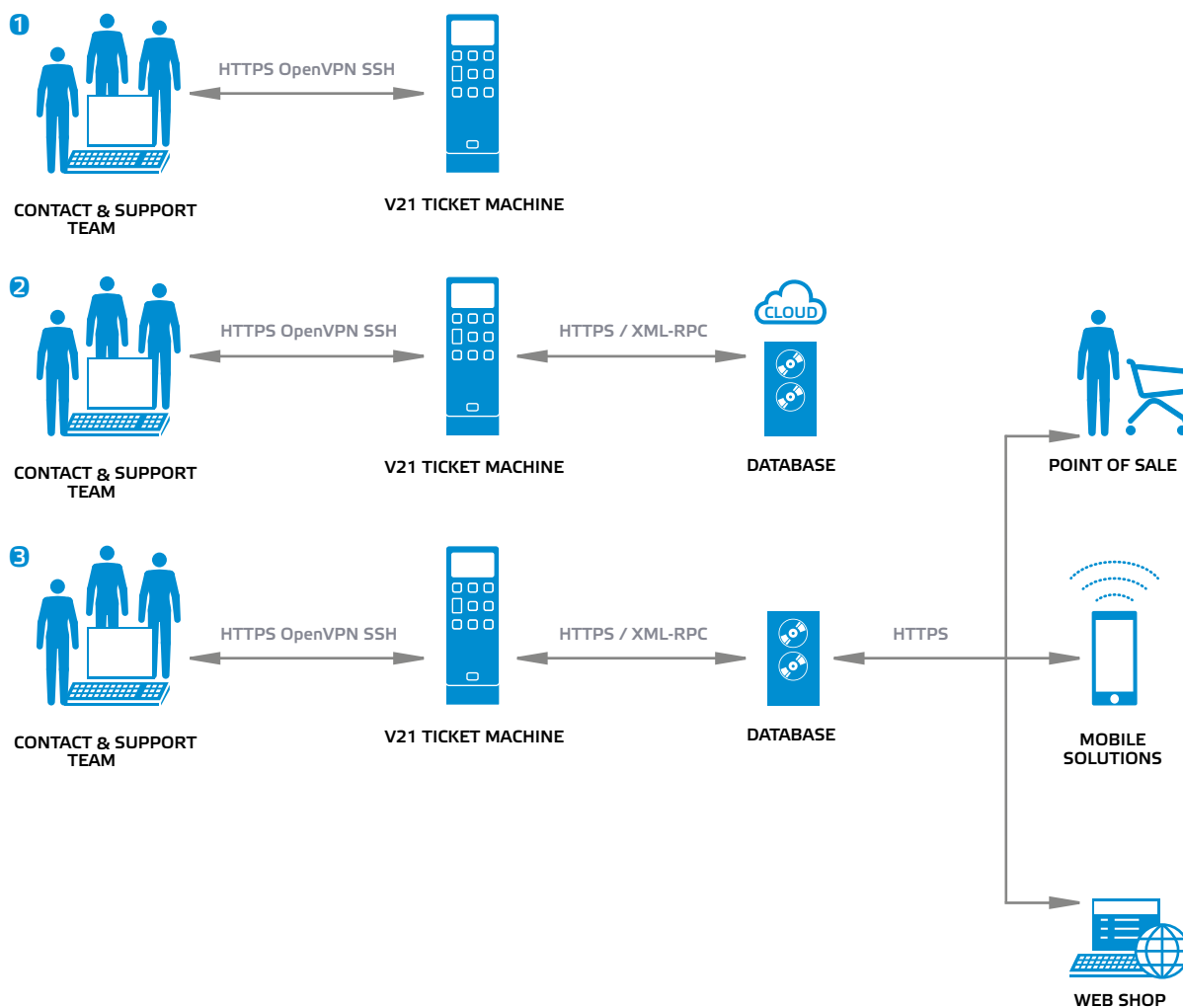

## Examples of implementation

The user interface is simple and well structured. It can be adapted to suit individual requirements depending on the application.





## 07.01 ETISS ERP

■ The new “ETISS ERP” management software manages all hardware components of the ticket machines and automates the individually specified technical requirements. All activities performed in connection with ticket machines are clearly mapped out and the user is supported in a wide variety of scenarios.



| V21 Ticket Machine Software Functions  |   |
|--|---|
| Innovative analysis tool   | ☑ |
| Supported operating systems: Windows, UNIX, iOS, Android   | ☑ |
| Kiosk user interface, supports SVG format  | ☑ |
| Role-based functions for cashiers, managers & administrators   | ☑ |
| Customised interfaces for tickets or product selection   | ☑ |
| Hardware error management through min/max definition matrix, automatic switch to maintenance mode when the specified tolerance range is exceeded | ☑ |
| Retention in a central database of all varying conditions such as payment operations, incident reports, hardware component statuses.             | ☑ |
| Protection against manipulation or opening without payment, by means of alarm management   | ☑ |
| Offline version without network support available  | ☑ |
| Multiple languages supported   | ☑ |
| Receipts issued in various languages   | ☑ |
| Central control of software updates  | ☑ |
| Encrypted communication within the network   | ☑ |
| Documentation of all events  | ☑ |
| GOBD standard certification  | ☑ |
| Remote access  | ☑ |

### Overview of services available to you

#### Security

- Encrypted, tamper-proof databases
- Password-protected system access
- Audit-proof processing of payment transactions
- Compliant with applicable legal requirements

#### Integration

- Stable availability under changing network conditions
- Standardised interfaces
- Easy to implement within existing IT structures
- 24/7 on-call service (optional)
- Proof of Concept (POC) before each implementation

#### Everything at a glance

- Statistics – comprehensive evaluation options in “real time”
- History – full documentation of all actions
- Serviceability – user-friendly, intuitive interface
- Early warning system – scalable alarm function

#### Flexibility

- Split screen function for advertising messages
- Video advertisements in standby mode
- User administration – customised user profiles/access rights
- Fault management – support via remote maintenance of machine

## 07.02 ETISS ERP with POS

Management of POS\_MADE\_BY\_WANZL

- > Support for custom-built ticket systems
- > Optimisation of operational processes
- > The ticket software adapts to individual requirements

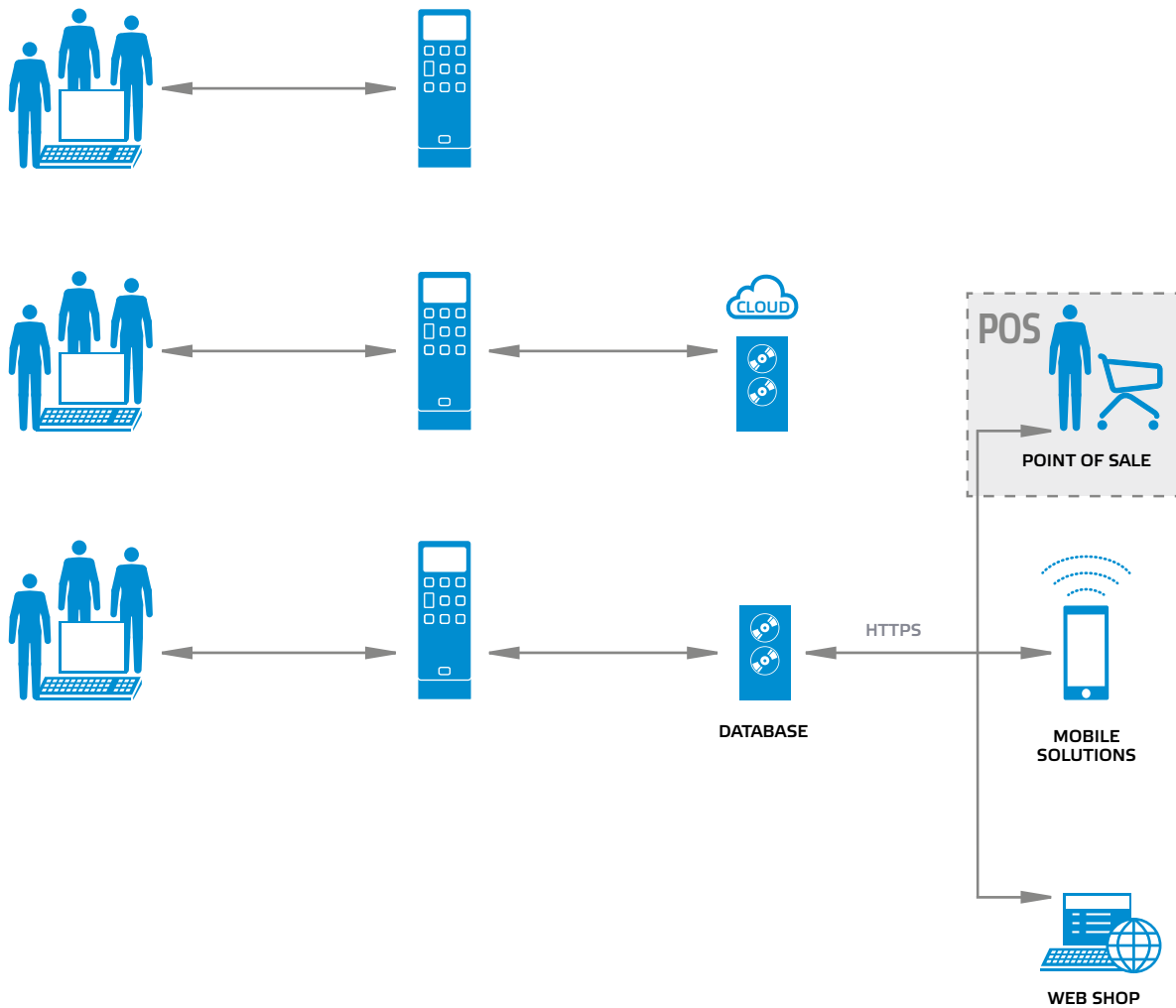

## 07.02 ETISS ERP with POS

■ The ETISS software can also be used **with ticket systems**. Customer-specific processes are taken into account and incorporated into ticket system planning.



| Point of Sale Software Functions   |   |
|--|---|
| Innovative analysis tool   | ☑ |
| Supported operating systems: UNIX  | ☑ |
| Kiosk user interface   | ☑ |
| Layout design in accordance with the customer's CI   | ☑ |
| Variable product selection with discount support, dynamic price lists, timing dependent presentation of objects for sale | ☑ |
| Stable communication with the server in the event of changing network conditions   | ☑ |
| Protection against manipulation of bookings  | ☑ |
| Offline version without network support available  | ☑ |
| Multiple languages supported   | ☑ |
| Receipts issued in various languages   | ☑ |
| Central control of software updates  | ☑ |
| Encrypted communication within the network   | ☑ |

### Hardware selection based on preferences

- A variety of ticket systems
- Payment machines
- Ticket printers
- Integration of existing hardware

# 07.03 ETISS NG

Management of cash hardware\_MADE\_BY\_WANZL

- > Support for all operating systems from a single line of development
- > Standardised interfaces for a variety of hardware components
- > Network capacity with centralised controls for all decentralised machines

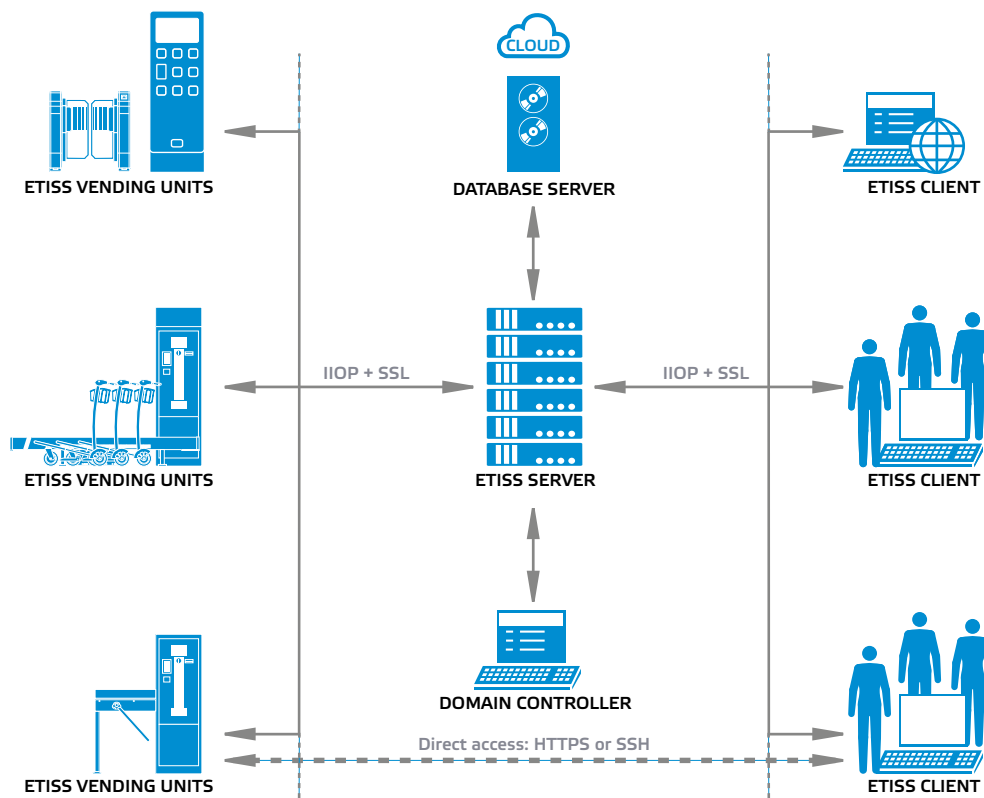

## Overview of services available to you

### Security

- Encrypted, tamper-proof databases
- Password-protected system access
- Audit-proof processing of payment transactions
- Compliant with applicable legal requirements

### Everything at a glance

- Statistics – comprehensive evaluation options in “real time”
- History – full documentation of all actions
- Serviceability – user-friendly, intuitive interface
- Early warning system – scalable alarm function

### Integration

- Stable availability under changing network conditions
- Standardised interfaces
- Easy to implement within existing IT structures
- 24/7 on-call service (optional)
- Proof of Concept (POC) before each implementation

### Flexibility

- Split screen function for advertising messages
- Video advertisements in standby mode
- User administration – customised user profiles/access rights
- Fault management – support via remote maintenance of the machines

## 07.03 ETISS NG

■ The new “**ETISS NG**” management software manages the premium hardware components in ticket machines, and thereby automates the associated work processes. All activities performed in connection with ticket machines are clearly mapped out and the user is supported in a wide variety of scenarios.

| Ticket machine Software functions   |      |
|---|------|
| Innovative analysis tool  | ☑    |
| Supported operating systems: Linux, Windows, OS X, Android  | ☑    |
| Support for automatic screen resolution   | ☑    |
| Encrypted communication between server and clients  | ☑    |
| Automatic software update   | ☑    |
| Automatic internal component firmware update  | ☑    |
| Remote maintenance via SSH Secure Shell   | ☑    |
| Web-based remote maintenance via HTTPS  | ☑    |
| Authorisation via three roles: administrators, cashiers and hardware managers   | ☑    |
| Machine configuration is amended using the touchscreen or SSH Secure Shell  | ☑    |
| A finite-state machine controls most of the machine's operations  | ☑    |
| Transfer of all actions and events to the server  | ☑    |
| Works autonomously if the connection to the server is lost  | ☑    |
| Minimal configuration if a few non-essential components are missing or have malfunctioned   | ☑    |
| Server Software functions   |      |
| Maximum number of machines  | 2000 |
| Automatic database maintenance  | ☑    |
| Automatic sending of database table datasets to an external destination, up to four times per day   | ☑    |
| Extensive logging at server level and machine level   | ☑    |
| Time correction via an SNTP server, automatic switching between summer and winter time  | ☑    |
| Client Software functions   |      |
| Kerberos or NTLM authentication   | ☑    |
| Authorisation via three roles: administrator, cashier and hardware manager  | ☑    |
| Adaptable layout  | ☑    |
| Symbols provide a wide range of information, e.g. network name, location, current sales unit status, course of status over time, current figures, current amount of money, etc. | ☑    |
| Detailed information on configuration, current status of the machine and the history of events and activities   | ☑    |
| Remote firmware update (including flash management for BNA and coin checkers)   | ☑    |
| Displayed text adaptation   | ☑    |
| User and service user management  | ☑    |
| Service user shift management   | ☑    |
| Hopper management   | ☑    |
| Status colour and priority adjustment   | ☑    |
| Course of credit card payment over time   | ☑    |
| Detailed drill-down report functions  | ☑    |
| Three-level site identification for sales units (terminals, sections and areas)   | ☑    |
| Set-up of sales machine receipts using a WYSIWYG designer   | ☑    |
| Extended global settings  | ☑    |
| Client  |      |
| Connection query via COMport  | ☑    |

# 07.04 ETOSS®

Centralised and intelligent management module for a variety of components

- > Management of output terminals, ticket machines and access control systems
- > Full control of all connected components
- > User-friendly interface with presentation in graphs

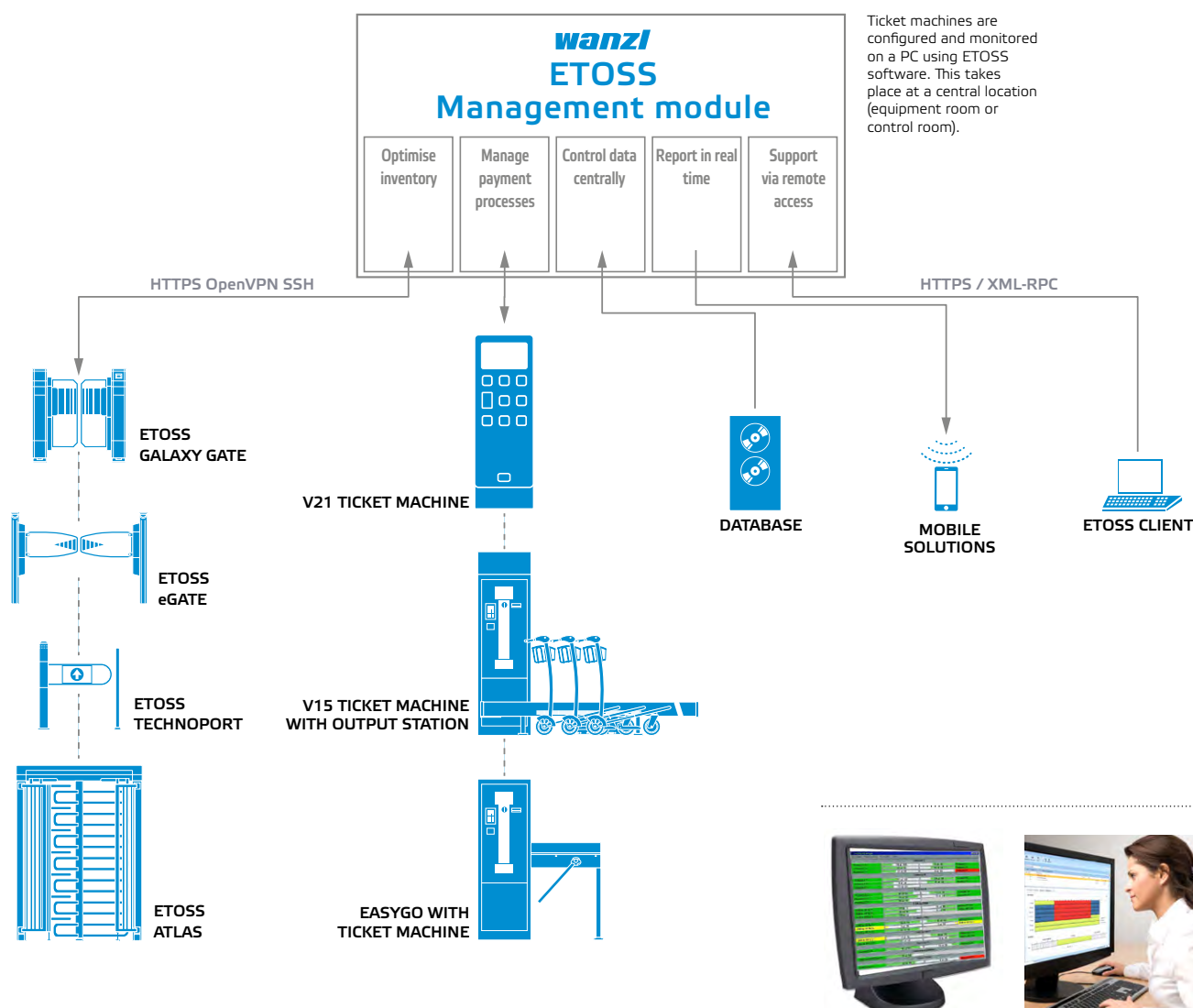

## The centralised ETOSS management module

The clear administration interface enables all tasks to be selected and individually adapted using the navigation window. All activities are supported with wizards to ensure easy operation. Statistics and graph-based status information are integrated into an existing web portal using a web monitor.

Central IT administration always has an overview of all output terminals and is, therefore, able to significantly increase productivity. The graphs offer excellent opportunities for analysis, thereby taking increased security and quality needs throughout the IT environment fully into account.

## 07.03 ETOSS®

■ Use ETOSS (Electronic Transaction-secure Operation Software and Service) management, and you will be able to monitor terminals with all the equipment features you can think of. Dynamic, graphical elements provide a full overview of operations. Meaningful statistics promote the transparency of the entire work process.

### *ETOSS Professional*

Software for **automated management of output terminals, ticket machines and access control systems.**

Whether you're using the equipment to identify your customers at service stations, in official organisations, at the gym, or for optimising trolley management at the airport, the user-friendly interface, central configuration elements and diverse statistics module makes ETOSS Professional the ideal management platform.

ETOSS uniformly maps the entire existing infrastructure. The software uses standard technologies and interfaces,

thereby enabling deep integration into existing technical framework conditions – without additional expenditure.

With diverse import and export opportunities, adapted statistics and graphical elements can be created and then used directly in the product web monitor. Support for implementation into existing web portals is exemplary. In environments with restricted access rights in particular, this type of visualisation offers an indispensable opportunity to present selected data content at a high level of quality.

### *Overview of advantages*

#### **Security**

- Encrypted, tamper-proof databases
- Password-protected system access
- Audit-proof processing of payment transactions
- Compliant with applicable legal requirements

#### **Integration**

- Robust and stable availability in the event of changing network conditions
- Compatibility with Microsoft Office and PDF format
- Easy to implement within existing IT structures

#### **Flexibility**

- User administration – individual user profiles and access rights
- Fault management – support via remote maintenance
- Modular architecture – a variety of components, homogeneous software

#### **Everything at a glance**

- Statistics – comprehensive evaluation options in “real time”
- History – full documentation of all actions
- Interface – user friendly and intuitive
- Early warning system – scalable alarm function

### *Building the software architecture*

The output terminal is fineuned to meet your needs and fulfils all the technical requirements of the respective process. The software provides different components with the same kind of support in the output terminals.

### *Web server system requirements*

- Operating system: Windows 2000, Windows XP, Windows 2003, Windows Vista, Windows 7, Windows 2008
- Hardware: minimum 256 MB RAM, CPU 1 GHz – depending on the scope of data

# wanzl

VISIT US AT  
[www.wanzl.com](http://www.wanzl.com)



**GERMANY**  
**Wanzl GmbH & Co. KGaA**  
Rudolf-Wanzl-Straße 4  
89340 Leipheim

Phone +49(0)8221/729-0  
[info@wanzl.com](mailto:info@wanzl.com)  
[www.wanzl.com](http://www.wanzl.com)

**GREAT BRITAIN**  
**Wanzl Ltd.**  
Europa House  
Heathcote Lane  
Warwick CV34 6SP

Phone +44(0)1926/451951  
[enquiries@wanzl.co.uk](mailto:enquiries@wanzl.co.uk)  
[www.wanzl.com](http://www.wanzl.com)

**AUSTRALIA**  
**Wanzl Australia Pty Ltd**  
3 Haymer Ct,  
Braeside VIC 3195

Phone +61(0)3/98082299  
[info.au@wanzl.com](mailto:info.au@wanzl.com)  
[www.wanzl.com](http://www.wanzl.com)



Dimensions in mm, specifications approximate, colours similar to RAL, design subject to changes.  
Illustrations may show optional equipment. © Wanzl GmbH & Co. KGaA 2023